

PROGRAMMA
IT
PROGRAMMA
YOD
PROGRAMMA
2000
PROGRAMMA
200
PROGRAMMA
200E
PROGRAMMA
200Q
PROGRAMMA
200P
PROGRAMMA
K-LOCK
PROGRAMMA
300
PROGRAMMA
M18
PROGRAMMA
100
PROGRAMMA
PVD
PROGRAMMA
P70



ADMEMBER
Industrial Design Association

ITALIANO

Se avete aperto una porta, vi siete affacciati su uno spettacolare vuoto urbano o vi è accaduto di attraversare ambienti liberi dagli irritanti intralci delle barriere architettoniche allora, avete impugnato una nostra idea. Siamo il brand dell'acciaio inox AISI 316L il più duro, resistente ed elastico tra gli acciai e della resina termoplastica poliammide 6, la più nobile. Sviluppiamo le nostre aree tematiche: le maniglie per porte e finestre, i maniglioni e i maniglioni con serratura, le balaustrate, le panchine ischiatiche e i supporti per il "vivere senza barriere", nella convinzione che gli oggetti dicano un ambiente, ne dichiarino il temperamento, le illusioni, le possibilità. Le forme "informano" e hanno effetti logici, modificano il mondo e dichiarano delle priorità. Per noi priorità è che – adesso – la bellezza è vera solo se si dà a tutti accessibile.

ENGLISH

If you've opened a door, you're bound to have seen a spectacular empty urban setting, or you may have strolled through environments free of annoying architectural barriers that block your way, and if you've done so – you've grasped our idea. We've made our name in AISI 316L stainless steel, the hardest, most resistant and elastic of steels, and in polyamide 6 thermoplastic resin, the noblest of plastics. We develop our themes: handles for doors and windows, pull handles, pull handles with lock, balustrades, ischial support benches and supports for "living without barriers", convinced that objects create an environment, its temperament, illusions, and possibilities. Forms "inform" and have logical effects, changing the world and establishing priorities. For us the priority is that – here and now – beauty is only real if it is accessible to all.

FRANCAIS

S'il vous est arrivé d'ouvrir une porte pour vous pencher sur un vide urbain spectaculaire, ou si vous eu l'occasion de parcourir des habitats libérés des obstacles irritants que représentent les barrières architecturales, alors vous avez pu saisir l'une de nos idées. Nous sommes la marque de l'acier inox AISI 316L le plus dur, le plus résistant et le plus élastique parmi les aciers, et de la résine thermoplastique polyamide 6, la plus noble. Nous développons nos différents thématiques: les poignées de portes et de fenêtres, les poignées de tirage et les poignées de tirage avec serrure, les garde-corps, les appuis ischiatiques et les supports afin de "vivre sans barrières", parce que nous sommes convaincus que les objets caractérisent un habitat en affirmant son tempérament, ses illusions et ses possibilités. Les formes "informent", elles ont des effets logiques, elles modifient le monde et déclarent des priorités. Pour nous, la priorité c'est que – maintenant – la beauté n'est authentique que si on la rend accessible à tous.

DEUTSCH

Wenn sie eine Tür öffnen, haben Sie entweder die Aussicht auf trübes, städtisches Einerlei oder es kann geschehen, dass sie sich durch Räume bewegen, die frei sind von irritierenden Hindernissen und architektonischen Barrieren. Dann halten Sie unsere Ideen in ihren Händen. Unseren „Brand“ AISI 316L in Edelstahl, der härteste, resistensteste und elastischste unter den Edeldstählen, sowie thermoplastischen Kunstharz Polyamid 6, der eleganteste Kunststoff. Unsere Weiterentwicklung umfasst alle Bereiche: Tür- und Fenstergriff, verschließbare Griffe, Handläufe und Geländer, variable Anlehnhilfen, sowie Hilfselemente für barrierefreies Leben. Wir sind der Überzeugung, dass die Objekte ein Ambiente kreieren sollen, welche dem Menschen die Möglichkeit gibt, sein Temperament, seine Träume und seine Fähigkeiten auszuleben und zu entfalten. Alle Formen sind logisch, schlüssig, sie sprechen für sich und verändern die Welt und ihre Umgebung durch ihre Vorzüge. Für uns hat Priorität, dass die Schönheit nur dann wahr ist, wenn sie auch für jeden erreichbar ist.

ESPAÑOL

Si ha abierto una puerta, se ha asomado a una baranda que da a una espectacular vista urbana o ha cruzado por lugares libres de esos enervantes obstáculos que crean las barreras arquitectónicas... en ese caso, se ha aferrado a una de nuestras ideas. Somos la marca del acero inoxidable AISI 316L – el más duro, el más resistente y elástico de los aceros – y de la poliamida 6 – la más noble de las resinas termoplásticas –. Desarrollamos nuestras áreas temáticas: las manillas para puertas y ventanas, los manillones con cerradura, las balaustradas, los apoyos isquiáticos y los soportes para una "vida sin barreras", convencidos como estamos de que los objetos hablan sobre un ambiente, declaran cuál es su temperamento, sus ilusiones, sus posibilidades. Las formas «informan» y tienen efectos lógicos, modifican el mundo y establecen prioridades. Nuestro pensamiento prioritario – ahora – es que la belleza es auténtica solamente cuando es accesible para todos.

NEDERLANDS

Als u een deur geopend hebt, als u zich voor een prachtige stadsleegte hebt bevonden, of als het u reeds overkomen is ruimtes te doorkruisen die vrij zijn van alle vervelende belemmeringen van architectonische barrières, dan zit u op onze golfengte. Wij zijn het merk van het roestvast staal AISI 316L, het hardste, meest bestendige en meest elastische van alle staalsoorten en van de thermoplastische polyamide 6, de nobelste van alle harssoorten. Wij ontwikkelen onze thema's: grepen voor deuren en vensters, voordeurgrepen en grepen met ingebouwde cilindrs, de balustrades, de ischiatische zitbanken en steunen voor het "leven zonder barrières", volgens de overtuiging dat de voorwerpen een omgeving verhalen, het temperament, de illusies en de mogelijkheden ervan verklaren. De vormen "geven informatie" en hebben logische gevolgen, wijzigen de wereld en stellen prioriteiten. Prioriteit is voor ons dat – nu – de schoonheid slechts waarlijk is wanneer ze voor iedereen toegankelijk is.

**TEST E CERTIFICAZIONI
TESTS AND CERTIFICATIONS
TESTS ET CERTIFICATIONS**
**TEST UN ZERTIFIKATEN
ENSAYOS Y CERTIFICACI^{ÓN} NES
TESTEN EN CERTIFICATEN**

ITALIANO

Grado di resistenza alla corrosione. Certificazione acciaio inossidabile AISI 316L.

ENGLISH

Resistance to Corrosion. Stainless steel AISI 316L certification.

FRANCAIS

Resistance à la corrosion. Certification acier inoxydable AISI 316L.

DEUTSCH

Korrosionsbeständigkeitsstufe. ZertifiKaten Edelstahl rostfrei Werkstoff 1.4404.

ESPAÑOL

Resistencia a la corrosión. Certificación acero inoxidable AISI 316L.

NEDERLANDS

Niveau roestweerstand. Certificaten roestvast staal AISI 316L.

Chemical compositions of AISI stainless steel grades

Material - Stainless steel	C %	Cr %	Ni %	Mo %
AISI 430 (1.4016)	0,12 max	14.0-18.0	/	/
AISI 304 (1.4301)	0,08 max	18.0-20.0	8.0-10.5	/
AISI 316 (1.4401)	0,08 max	16.0-18.0	10.0-14.0	2.00-3.00
AISI 316L (1.4404)*	0,03 max	16.0-18.0	10.0-14.0	2.00-3.00

*Standard Pba

Estimated pit corrosion penetration time – time to penetrate 1 mm (years) by steel type

Location - Stainless Steel	Marine	Semi-industrial	Rural
Stainless steel AISI 430 (1.4016)	N/A	85	250
Stainless steel AISI 304 (1.4301)	145	135	770
Stainless steel AISI 316 (1.4401)	260	525	1200

Source: The British Stainless Steel Association [BSSA]

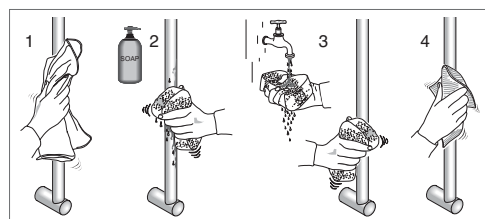
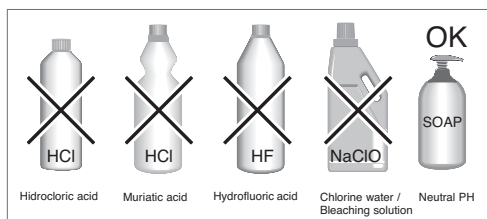
ITALIANO

CONSIGLI PER UNA CORRETTA PULIZIA DEI PRODOTTI IN ACCIAIO INOSSIDABILE

ENGLISH

ADVICE FOR A CORRECT MAINTENANCE OF THE PRODUCTS IN STAINLESS STEEL

FRANCAIS

CONSEILLES POUR UN NETTOYAGE CORRECT DES PRODUITS EN ACIER INOXYDABLE

DEUTSCH

RATSCHLÄGE FÜR EINE KORREKTE REINIGUNG DER PRODUKTEN AUS EDELSTAHL ROSTFREI

ESPAÑOL

CONSEJOS PARA UNA CORRECTA LIMPIEZA DE LOS PRODUCTOS DE ACERO INOXIDABLE

NEDERLANDS

RAADGEVINGEN VOOR EEN CORRECT ONDERHOUD VAN ROESTVAST STALEN PRODUCTEN

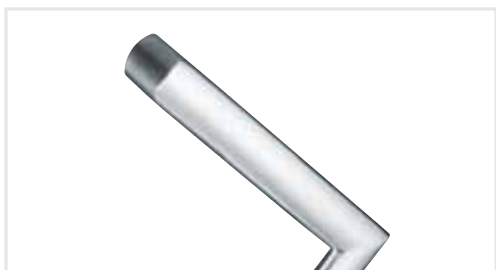
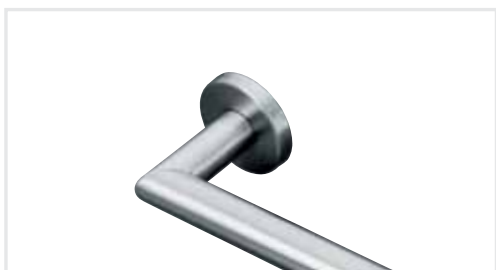
ITALIANO

Indice	Pagina
PROGRAMMA IT ACCIAIO INOX AISI 316L	6
Maniglie - Placche - Dreh-kipp - Bocchette - Chiusini	
Maniglioni	
PROGRAMMA YOD LEGNO E ACCIAIO INOX AISI 316L	20
Maniglie - Placche - Dreh-kipp - Chiusini - Maniglioni	
PROGRAMMA 2000 ACCIAIO INOX AISI 316L	34
Maniglie - Placche - Dreh-kipp - Bocchette	
Pomoli fissi - Pomoli girevoli - Chiusini	
Maniglie per alzante scorrevole	
Combinazioni: pomolo-maniglia-placca	
Maniglia fissa su placca - Maniglia ad incasso	
Fermaporta e appendiabiti	
Numeri e lettere - Pittogrammi	
PROGRAMMA 200 ACCIAIO INOX AISI 316L	66
Maniglioni tubolari tondi	
PROGRAMMA 200E ACCIAIO INOX AISI 316L	78
Maniglioni tubolari ellittici	
PROGRAMMA 200Q ACCIAIO INOX AISI 316L	84
Maniglioni tubolari con profilo quadrato	
PROGRAMMA 200P ACCIAIO INOX AISI 316L	88
Maniglioni con profilo piatto	
PROGRAMMA K-LOCK ACCIAIO INOX AISI 316L	94
Maniglioni con serratura	
PROGRAMMA 300 NYLON	108
Maniglioni	
Maniglie - Dreh-kipp - Chiusini - Bocchette	
PROGRAMMA M18 ALLUMINIO	120
Maniglioni	
PROGRAMMA 100 OTTONE	128
Maniglioni	
PROGRAMMA PVD ACCIAIO INOX AISI 316L E PVD	136
Maniglioni	
PROGRAMMA P70	144
Accessori per finestre	

ENGLISH

Index	Page
PROGRAMMA IT STAINLESS STEEL AISI 316L	6
Lever handles - Plates - Window handles	
Escutcheons - Snib indicators - Pull handles	
PROGRAMMA YOD WOOD AND STAINLESS STEEL AISI 316L	20
Lever handles - Plates - Window handles	
Snib indicators - Pull handles	
PROGRAMMA 2000 STAINLESS STEEL AISI 316L	34
Lever handles - Plates - Window handles - Escutcheons	
Fixed knobs - Turning knobs - Snib indicators	
Handles for lift and slide patio doors	
Sets: knob-lever handle-plate	
Fixed handle on plate - Flush handle	
Door stop and cloth hook	
Numbers and letters	
Pictograms	
PROGRAMMA 200 STAINLESS STEEL AISI 316L	66
Round tubular pull handles	
PROGRAMMA 200E STAINLESS STEEL AISI 316L	78
Elliptical tubular pull handles	
PROGRAMMA 200Q STAINLESS STEEL AISI 316L	84
Tubular pull handles with square profile	
PROGRAMMA 200P STAINLESS STEEL AISI 316L	88
Flat profile pull handles	
PROGRAMMA K-LOCK STAINLESS STEEL AISI 316L	94
Pull handles with lock	
PROGRAMMA 300 NYLON	108
Pull handles	
Lever handles - Window handles - Snib indicators - Escutcheons	
PROGRAMMA M18 ALUMINIUM	120
Pull handles	
PROGRAMMA 100 BRASS	128
Pull handles	
PROGRAMMA PVD STAINLESS STEEL AISI 316L AND PVD	136
Pull handles	
PROGRAMMA P70	144
Accessories for windows	

FRANCAIS

Index	Page
PROGRAMMA IT ACIER INOXIDABLE AISI 316L	6
Poignées - Plaques - Béquille de fenêtres - Entrées Dispositifs de fermeture - Poignées de tirage	
PROGRAMMA YOD BOIS ET ACIER INOXIDABLE AISI 316L	20
Bequilles - Plaques - Béquille de fenêtres Dispositifs de fermeture - Poignées de tirage	
PROGRAMMA 2000 ACIER INOXIDABLE AISI 316L	34
Bequilles - Plaques - Béquille de fenêtres - Entrées Boutons fixes - Boutons tournants - Dispositifs de fermeture Bequilles pour montant coulissant Combinaisons: bouton-bequille-plaque Bequille fixe montée sur plaque - Bequille encastrée Arrêt de porte et porte-manteaux - Chiffres et lettres - Pictogram.	
PROGRAMMA 200 ACIER INOXIDABLE AISI 316L	66
Poignées tubulaires rondes	
PROGRAMMA 200E ACIER INOXIDABLE AISI 316L	78
Poignées tubulaires elliptiques	
PROGRAMMA 200Q ACIER INOXIDABLE AISI 316L	84
Poignées tubulaires avec profil carré	
PROGRAMMA 200P ACIER INOXIDABLE AISI 316L	88
Poignées avec profil plat	
PROGRAMMA K-LOCK ACIER INOXIDABLE AISI 316L	94
Poignées de tirage avec serrure	
PROGRAMMA 300 NYLON	108
Poignées Poignées - Béquilles de fenêtres - Dispositifs de fermeture - Entrées	
PROGRAMMA M18 ALUMINIUM	120
Poignées	
PROGRAMMA 100 LAITON	128
Poignées	
PROGRAMMA PVD ACIER INOXIDABLE AISI 316L ET PVD	136
Poignées	
PROGRAMMA P70	144
Accessoires pour fenêtres	

DEUTSCH

Index	Seite
PROGRAMMA IT E-STAHl ROSTFREI 1.4404	6
Türdrückergarnituren - Schildern - Fenstergriffen Schlüsselschilder - Bad/WC Verriegelungen - Stossgriffen	
PROGRAMMA YOD HOLZ UND E-STAHl ROSTFREI 1.4404	20
Türdrückergarnituren - Schildern - Fenstergriffen Bad/WC Verriegelungen - Stossgriffen	
PROGRAMMA 2000 E-STAHl ROSTFREI 1.4404	34
Türdrückergarnituren - Schildern - Fenstergriffen Schlüsselschilder - Türkнопfen feststehend Türkнопfen drehbar - Bad/WC Verriegelungen Drücker mit Einlassmuschel für Schiebetüren Wechselgarnituren: Türkнопf - Türdrücker - Schilder Griffe auf Schilder - Einlassmuschel auf Schilder Bodentürpuffer - Türstopper und Wandhaken Nummern und Buchstaben - Pictogramme	
PROGRAMMA 200 E-STAHl ROSTFREI 1.4404	66
Stossgriffen rund	
PROGRAMMA 200E E-STAHl ROSTFREI 1.4404	78
Stossgriffen ellipsenförmig	
PROGRAMMA 200Q E-STAHl ROSTFREI 1.4404	84
Stossgriffen mit quadratischem Profil	
PROGRAMMA 200P E-STAHl ROSTFREI 1.4404	88
Stossgriffen mit Flachprofil	
PROGRAMMA K-LOCK E-STAHl ROSTFREI 1.4404	94
Stossgriffen mit Schloss	
PROGRAMMA 300 NYLON	108
Stossgriffen Türdrücker - Fenstergriffen - Verriegelungen - Schlüsselschilder	
PROGRAMMA M18 ALUMINIUM	120
Stossgriffen	
PROGRAMMA 100 MESSING	128
Stossgriffen	
PROGRAMMA PVD E-STAHl ROSTFREI 1.4404 UND PVD	136
Stossgriffen	
PROGRAMMA P70	144
Zubehöre für Fenstern	

ESPAÑOL

Indice	Página
PROGRAMMA IT ACERO INOXIDABLE AISI 316L	6
Manillas - Placas - Dreh-kipp - Bocallaves Muletillas - Manillones	
PROGRAMMA YOD MADERA Y ACERO INOXIDABLE AISI 316L	20
Manillas - Placas - Dreh-kipp - Muletillas - Manillones	
PROGRAMMA 2000 ACERO INOXIDABLE AISI 316L	34
Manillas - Placas - Dreh-kipp - Bocallaves Pomos fijos - Pomos móviles - Muletillas Manillas para correderas elevables Combinaciones: pomo - manilla - placa Manilla fija montada en placa - Manilla empotrada Tope de puerta y colgadores Números y letras - Pictogramas	
PROGRAMMA 200 ACERO INOXIDABLE AISI 316L	66
Manillones tubulares circulares	
PROGRAMMA 200E ACERO INOXIDABLE AISI 316L	78
Manillones tubulares elípticos	
PROGRAMMA 200Q ACERO INOXIDABLE AISI 316L	84
Manillones tubulares de perfil cuadrado	
PROGRAMMA 200P ACERO INOXIDABLE AISI 316L	88
Manillones de perfil plano	
PROGRAMMA K-LOCK ACERO INOXIDABLE AISI 316L	94
Manillones con cerradura	
PROGRAMMA 300 NYLON	108
Manillones Manillas - Dreh kipp - Muletillas - Bocallaves	
PROGRAMMA M18 ALUMINIO	120
Manillones	
PROGRAMMA 100 LATÓN	128
Manillones	
PROGRAMMA PVD ACERO INOXIDABLE AISI 316L Y PVD	136
Manillones	
PROGRAMMA P70	144
Accesorios para ventanas	

NEDERLANDS

Index	Pagina
PROGRAMMA IT ROESTVAST STAAL AISI 316L	6
Krukken - Schilden - Draai-kiep - Sleutelentrees WC vergrendelingen - Deurgrepen	
PROGRAMMA YOD HOUT EN ROESTVAST STAAL AISI 316L	20
Krukken - Schilden - Draai-kiep - Deurgrepen WC vergrendelingen - Deurgrepen	
PROGRAMMA 2000 ROESTVAST STAAL AISI 316L	34
Krukken - Schilden - Draai-kiep - Sleutelentrees Vaste deurknoppen - Draaibare deurknoppen WC vergrendelingen - Handgrepen voor hetschuifdeuren Combinaties: knop - kruk - schild Vaste greep op schild Inkapschelp - Deurstop en kapstok Cijfers en letters - Pictogrammen	
PROGRAMMA 200 ROESTVAST STAAL AISI 316L	66
Ronde buisvormige deurgrepen	
PROGRAMMA 200E ROESTVAST STAAL AISI 316L	78
Ovale buisvormige deurgrepen	
PROGRAMMA 200Q ROESTVAST STAAL AISI 316L	84
Vierkante buisvormige deurgreep	
PROGRAMMA 200P ROESTVAST STAAL AISI 316L	88
Plat profiel deurgreep	
PROGRAMMA K-LOCK ROESTVAST STAAL AISI 316L	94
Deurgrepen met slot	
PROGRAMMA 300 NYLON	108
Deurgrepen Deurkrukken - Draai-kiep - WC vergrendelingen - Sleutelentrees	
PROGRAMMA M18 ALUMINIUM	120
Deurgrepen	
PROGRAMMA 100 MESSING	128
Deurgrepen	
PROGRAMMA PVD ROESTVAST STAAL AISI 316L	136
EN PVD AFWERKING	
Deurgrepen	
PROGRAMMA P70	144
Toebehoren voor ramen	

PROGRAMMA IT

PHOTO: Gabriele Basilico

ITALIANO
PROGRAMMA IT

Maniglie, maniglioni e complementi in acciaio inox AISI 316L dalla forma essenziale realizzati con la collaborazione dei designer Tiberio Cerato e Mario Tassarollo.

Rigorosamente made in Italy.

Il Programma IT usa fissaggi che permettono il montaggio singolarmente o in coppia di tutti i modelli su qualunque tipologia di materiale (Legno, Metallo, PVC e Vetro).

Finitura standard: satinata.

Finitura a richiesta: lucida.

Maniglioni speciali a richiesta (art.xxx/A).

ENGLISH
PROGRAMMA IT

Lever handle, pull handles and accessories in stainless steel AISI 316L with a design evolved in collaboration with the designers Tiberio Cerato and Mario Tassarollo.

Precision manufactured in Italy. The Programma IT fixings permit simple or back to back installation on all models and have been designed to fit any type of material (wood, PVC, metal, glass).

Standard finishing: satin

Finishing by request: bright

Special pull handles on request (art.xxx/A).

FRANCAIS
PROGRAMMA IT

Bequilles, poignées de tirage et accessoires de finition en acier inoxydable AISI 316L avec une forme innovante réalisés avec la collaboration des designers Tiberio Cerato et Mario Tassarollo.

Exclusivement made in Italy. Les fixations du Programma IT peuvent être montées seules ou par paire sur tous les modèles et sur tout type de portes (bois, PVC, métal et verre).

Finition standard: satinée

Finition sur demande: polie

Poignées de tirage spéciales sur demande (art.xxx/A).

DEUTSCH
PROGRAMMA IT

Türdrücker, Baubeschläge und Stoßgriffen mit einem modernen Design und aus Edelstahl rostfrei Werkstoff 1.4404. Diese Serie ist das Ergebnis von der Mitarbeit der Architekten Tiberio Cerato und Mario Tassarollo und Made in Italy.

Das Programma IT ermöglicht entweder eine Einzel- sowie eine Paarweisebefestigung auf Türen und Sonderkonstruktionen aller Art (Holz, Kunststoff, Metall, Glas, Türrahmen aus Aluminium, usw).

Standardausführung: Matt satiniert

Hochglanz polierte Ausführung auf Anfrage lieferbar

Stoßgriffen mit einem Sondermass auf Anfrage lieferbar (art.xxx/A).

ESPAÑOL
PROGRAMMA IT

Manillas, manillones y complementos en acero inoxidable AISI 316L de forma esencial realizados con la colaboración de los diseñadores Tiberio Cerato y Mario Tassarollo.

Rigorosamente hecho en Italia. Las fijaciones del Programma IT pueden montarse individualmente o a juego de tutti i modelli in qualsiasi tipo di materiale (madera, metal, PVC y cristal).

Acabados en serie: satinado

Acabados bajo petición : brillante

Manillones especiales bajo pedido (art.xxx/A).

NEDERLANDS
PROGRAMMA IT

Deurkrukken, accessoires en deurgrepen in roestvast staal AISI 316L met een hedendaags uniek design. De vormgeving werd verzorgd in samenwerking met Tiberio Cerato en Mario Tassarollo. Uitsluitend gefabriceerd in Italië. Het Programma IT gebruikt bevestigingen die het mogelijk maken om iedere greep zowel enkel als per paar te bevestigen op elk materiaal (Hout, Metaal, PVC of glas).

Standaardafwerking: mat geborsteld

Afwerking op aanvraag: blinkend gepolijst

Deurgrepen op maat op aanvraag (art. xxx/A).

PROGRAMMA IT
ITALIANO

Specifiche d'ordine	Codici	Confezioni standard	
Per tutti gli articoli: Codice articolo Tipologia di finitura Tipo di fissaggio	S= Satinato P= Lucido	Maniglioni Maniglie Dreh-kipp Chiusini	2 Pezzi 1 Coppia 10 Pezzi 10 Pezzi
Fissaggi			Pagina 19

ENGLISH

Order specifics	Codes	Standard Packing	
For all articles: Article code Type of finish Fitting code	S= Satin finish P= Bright finish	Pull handles Lever handles Dreh-kipp Snib indicators	2 Pieces 1 Pair 10 Pieces 10 Pieces
Fixings			Page 19

FRANCAIS

Caractéristiques de la commande	Codes	Emballage standard	
Pour tous les articles: Code article Typologie de finition Code fixation	S= SatinÉ P= Poli	Poignées Béquilles Dreh-kipp Verrous	2 Pièces 1 Pair 10 Pièces 10 Pièces
Fixation			Page 19

DEUTSCH

Bestellangabe	Zusatzcode	Packeinheit zstück	
Für alle Artikel: Artikelnummer Ausführung Befestigungsart	S= Fein matt Satiniert P= Hochglanz poliert	Stossgriffe Türdrücker Fenstergriffe Baderosetten	2 Stück 1 Paar 10 Stück 10 Stück
Befestigungen			Seite 19

ESPAÑOL

Características del pedido	Código	Confección estándar	
Para todos los artículos: Código artículo Tipo de acabado Código fijación	S= Satinado P= Brillante	Manillones Manillas Dreh-kipp Cierres	2 Piezas 1 Juego 10 Piezas 10 Piezas
Fijaciones			Pagina 19

NEDERLANDS

Besteiddetails	Code	Standaardverpakking	
Voor alle artikelen: Artikelcode Afwerkingstype Bevestigingstype	S= mat geborsteld P= blinkend geborsteld	Deurgrepen Deurrukken Draaikiep WC-Vergrendelingen	2 Stuks 1 Paar 10 Stuks 10 Stuks
Bevestiging			Pagina 19

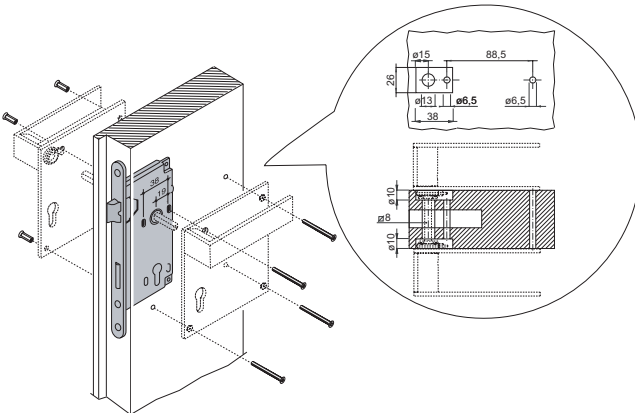
MANIGLIE - LEVER HANDLES - BEQUILLES - TÜRDRÜCKER - MANILLAS - KRUKKEN

Usare esclusivamente serrature provviste di fori per il fissaggio delle maniglie con viti passanti.

Exclusively use locks with holes to fix lever handles with through screws.

Utiliser exclusivement des serrures avec trous pour le fixage de béquilles avec vis passantes.

Ausschliesslich Verschlüsse mit Bohrungen für die durchgehende Verschraubung der Türdrücken zu verwenden.

Usar exclusivamente cerraduras provistas de orificios para fijar manillas con tornillos pasantes.

Enkel patentsloten, voorzien voor doorgaande bevestiging, gebruiken.

SISTEMA DI FISSAGGIO ANTIEFFRAZIONE PER FISSAGGI "SERIE/D" (BREVETTATO)

ANTI BREAK-IN FIXING SYSTEM FOR FIXING "SERIE/D" (PATENTED)

SYSTÈME DE FIXATION ANTI EFFRACTION POUR FIXATION "SERIE/D" (BREVETE)

BEFESTIGUNGSSET DIEBSTAHSICHER FÜR BEFESTIGUNGEN "SERIE/D" (PATENTIERT)

SISTEMA DE FIJACIÓN ANTISABOTAJE PARA FIJACIONES "SERIE/D" (BREVETADO)

ANTIVANDALISMEBEVESTIGING VOOR BEVESTIGING "SERIE/D" (GEBREVETTEERD)

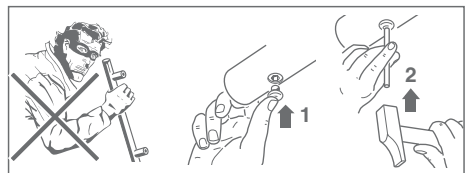

DESIGN TIBERIO CERATO E MARIO TESSAROLLO

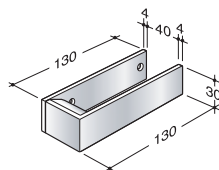

ART. 2001.IT

DESIGN TIBERIO CERATO E MARIO TESSAROLLO

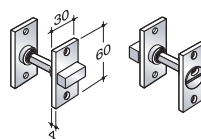

ART. 2001.IT.CH

DESIGN TIBERIO CERATO E MARIO TESSAROLLO

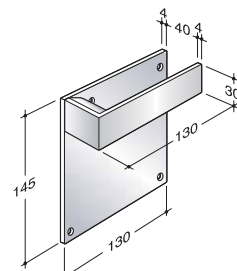

ART. 2001.IT.PLA

DESIGN TIBERIO CERATO E MARIO TESSAROLLO

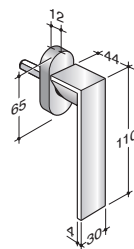

ART. 2001.IT.DK

PROGRAMMA IT

DESIGN TIBERIO CERATO E MARIO TESSAROLLO

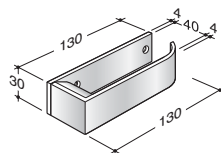

ART. 2001B.IT

DESIGN TIBERIO CERATO E MARIO TESSAROLLO

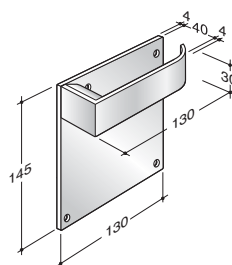

ART. 2001B.IT.PLA

DESIGN TIBERIO CERATO E MARIO TESSAROLLO

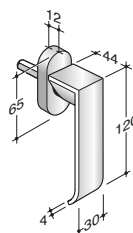

ART. 2001B.IT.DK

DESIGN TIBERIO CERATO E MARIO TESSAROLLO

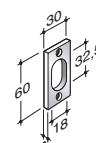
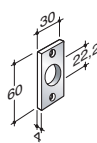
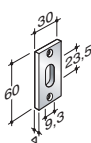
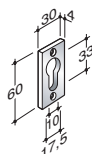

ART. 2001B.IT.Y

ART. 2001B.IT.P

ART. 2001B.IT.C

ART. 2001B.IT.U

PROGRAMMA IT

DESIGN TIBERIO CERATO E MARIO TESSAROLLO

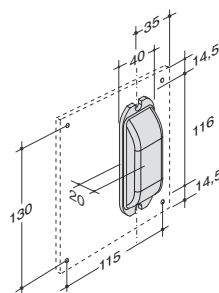
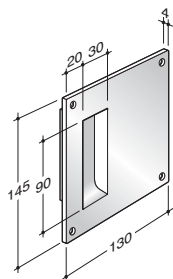
ART. 2001.IT.SC

DESIGN TIBERIO CERATO E MARIO TESSAROLLO

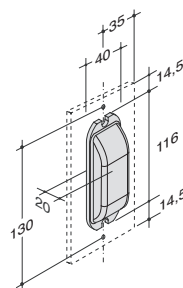
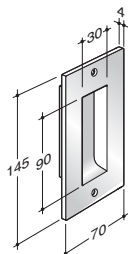
ART. 2001.IT.SC/P

DESIGN TIBERIO CERATO E MARIO TESSAROLLO

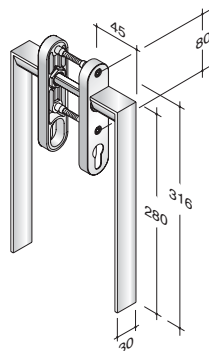
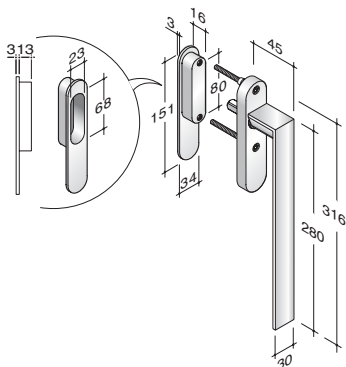
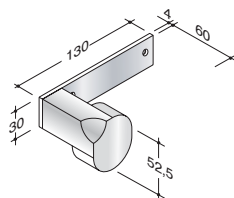

ART. 2001.IT.AS
ART. 2001.IT.DK

ART. 2001.IT.PM/F

PROGRAMMA IT

DESIGN TIBERIO CERATO E MARIO TESSAROLLO

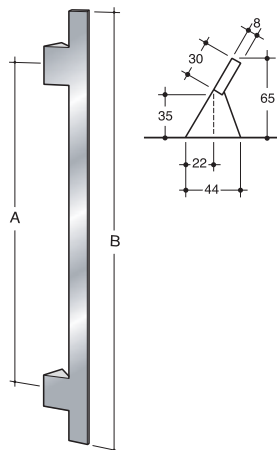

ART.	A	B
200.IT.001	350	520
200.IT.002	550	720
200.IT.002/A		



DESIGN TIBERIO CERATO E MARIO TESSAROLLO



ART.	A	B
200.IT.011	350	410
200.IT.012	550	610
200.IT.012/A		

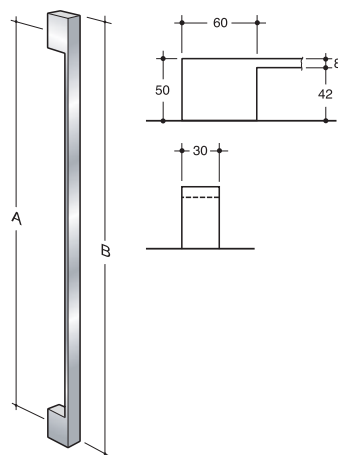



ART.	A	B
200.IT.021	350	500
200.IT.022	550	700
200.IT.022/A		

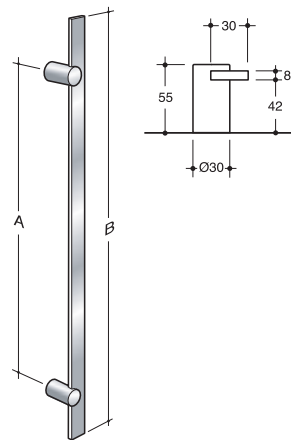

ART.	A	B
200.IT.031	350	500
200.IT.032	550	700
200.IT.032/A		

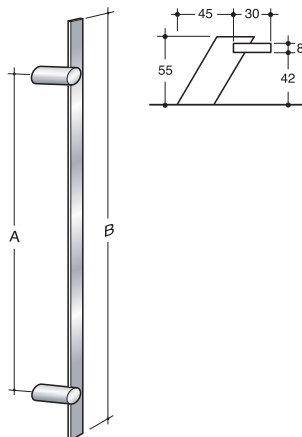



ART.	A	B
200.IT.041	350	500
200.IT.042	550	700
200.IT.042/A		

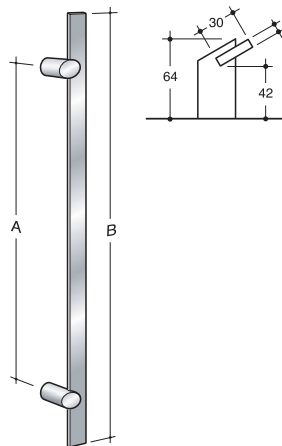

ART.	A	B	Ø
200.IT.051	350	500	25
200.IT.052	550	700	25
200.IT.052/A			

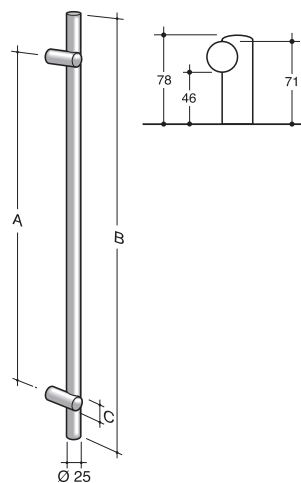



ART.	A	B	Ø
200.IT.061	350	500	30
200.IT.062	550	700	30
200.IT.062/A			

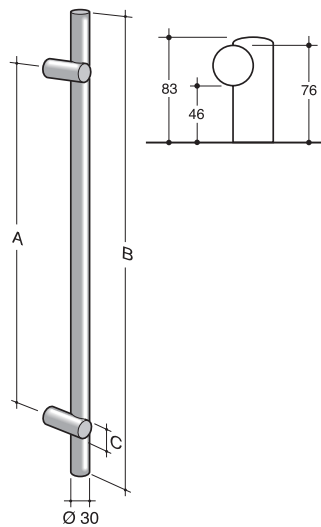

ART.	A	B
200.IT.071	350	400
200.IT.072	550	600

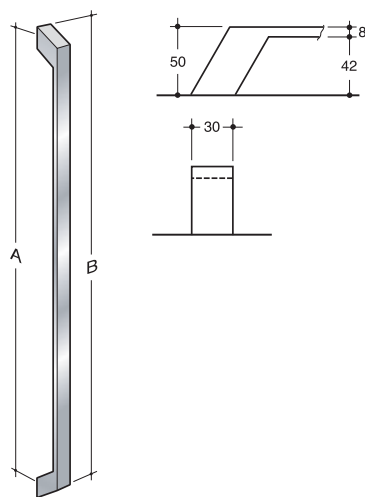

ART.	A	B
200.IT.081	350	380

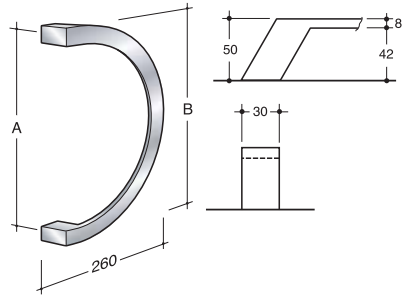

ART.	A	B	C
200.IT.082	500	550	95
200.IT.083	700	760	105

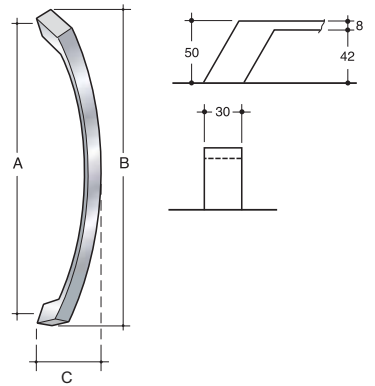



ART.	A	B
200.IT.091	350	500
200.IT.092	550	700
200.IT.092/A		

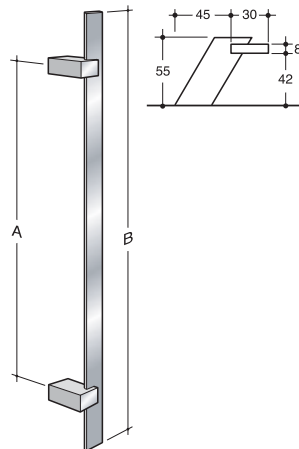

ART.	A	B
200.IT.101	350	500
200.IT.102	550	700
200.IT.102/A		

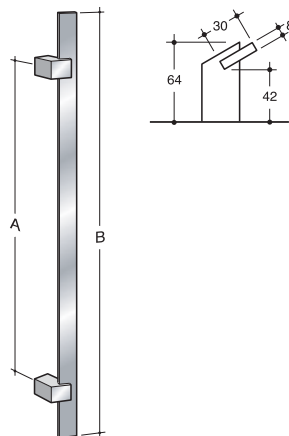

ART.	A	B
200.IT.121	1300	1410

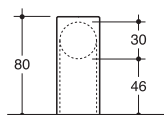
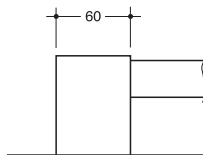
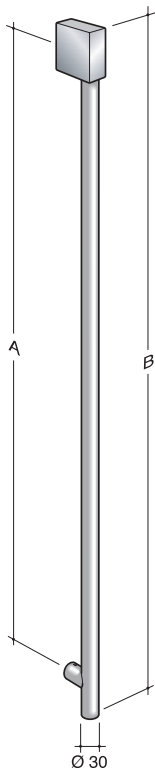

ART.	A	B	Ø
200.IT.111	1200	1370	30
200.IT.112	1200	1380	35

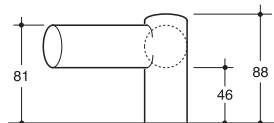
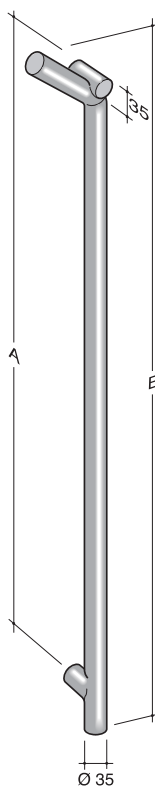
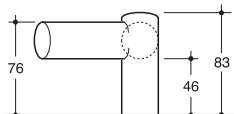
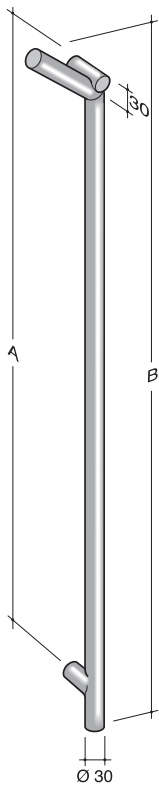

FISSAGGI SERIE /D
FIXINGS SERIES /D
FIXATIONS SERIE /D

BEFESTIGUNGEN SERIE /D
FIJACIONES SERIE /D
BEVESTIGING SERIE /D

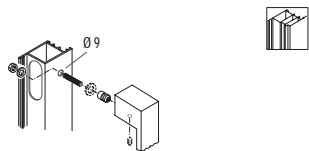

ART. 610/D-INOX

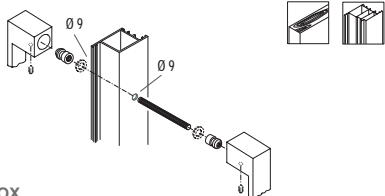

ART. 710/D-INOX

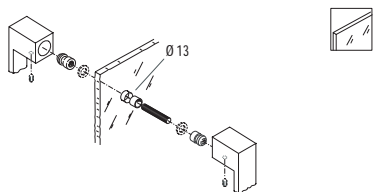

ART. 810/D-INOX

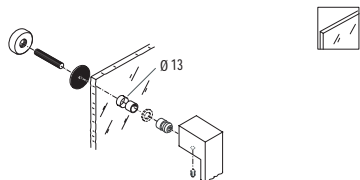

ART. 1012/D-INOX

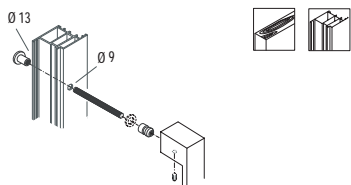

ART. 1110/D-INOX

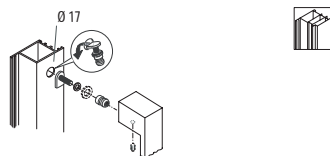

ART. 1210/D-INOX

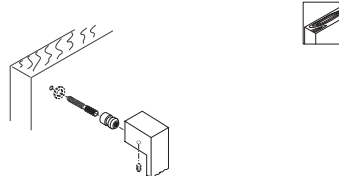

ART. 1310/D-INOX

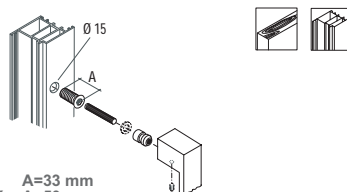

ART. 1410/D-INOX A=33 mm
ART. 1410/DL-INOX A=50 mm

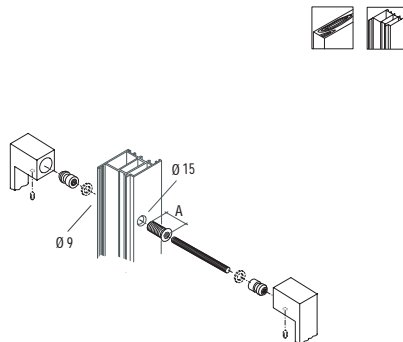

ART. 1510/D-INOX A=33 mm
ART. 1510/DL-INOX A=50 mm

LEGENDA - KEY TO SYMBOL - LÉGENDE - ZEICHENERKLÄRUNG - LEYENDA - LEGENDE

Legno
Wood
Holz
Bois
Madera
Hout

Alluminio / Pvc
Aluminium / Pvc
Aluminium / Pvc
Aluminium / Pvc
Aluminium / Pvc

Vetro
Glass
Verre
Glass
Cristal
Glas
Spessori per protezione vetro in dotazione
Glass protections included
Protections pour verre incluses
Schutzteilen für Glas im Lieferumfang enthalten
Juntas de protección para cristal incluidas
Glasbeschermingsrubbers meegeleverd in de verpakking

PROGRAMMA YOD

PHOTO: Gabriele Basilio

ITALIANO
PROGRAMMA YOD

Maniglie, maniglioni e complementi in legno e acciaio inox AISI 316L. Rigorosamente made in Italy.

Il Programma YOD usa fissaggi che permettono il montaggio singolarmente o in coppia di tutti i modelli su qualunque tipologia di materiale (Legno, Metallo, PVC e Vetro).

Finitura standard: satinata.

Finitura a richiesta: lucida.

DEUTSCH
PROGRAMMA YOD

Türdrücker, Baubeschläge und Stoßgriffen aus Holz und Edelstahl rostfrei Werkstoff 1.4404. Diese Serie ist Made in Italy.

Das Programma YOD ermöglicht entweder eine Einzel- sowie eine Paarweisebefestigung auf Türen und Sonderkonstruktionen aller Art (Holz, Kunststoff, Metall, Glas, Türrahmen aus Aluminium, usw).

Standardausführung: Matt satiniert

Hochglanz polierte Ausführung auf Anfrage lieferbar

ENGLISH
PROGRAMMA YOD

Lever handle, pull handles and accessories in wood and stainless steel AISI 316L. Precision manufactured in Italy. The Programma YOD fixings permit simple or back to back installation on all models and have been designed to fit any type of material (wood, PVC, metal, glass).

Standard finishing: satin

Finishing by request: bright

ESPAÑOL
PROGRAMMA YOD

Manillas, manillones y complementos en madera y acero inoxidable AISI 316L. Rigurosamente hecho en Italia. Las fijaciones del Programma YOD pueden montarse individualmente o a juego de tutti i modelli en puertas de cualquier tipología (madera, metal, PVC y cristal).

Acabados en serie: satinado

Acabados bajo petición: brillante

FRANCAIS
PROGRAMMA YOD

Bequilles, poignées de tirage et accessoires de finition en bois et acier inoxydable AISI 316L. Exclusivement made in Italy. Les fixations du Programma YOD peuvent être montées seules ou par paire sur tous les modèles et sur tout type de portes (bois, PVC, métal et verre).

Finition standard: satinée

Finition sur demande: polie

NEDERLANDS
PROGRAMMA YOD

Deurkrukken, accessoires en deurgrepen in hout en roestvast staal AISI 316L. Uitsluitend gefabriceerd in Italië. Het Programma YOD gebruikt bevestigingen die het mogelijk maken om iedere greep zowel enkel als per paar te bevestigen op elk materiaal (Hout, Metaal, PVC of glas).

Standaardafwerking: mat geborsteld

Afwerking op aanvraag: blinkend gepolijst

PROGRAMMA YOD
ITALIANO

Specifiche d'ordine	Codici	Confezioni standard
Per tutti gli articoli: Codice articolo Codice essenza legno Tipologia di finitura acciaio Tipo di fissaggio	S = Satinato P = Lucido	Maniglia Maniglie Dreh-kipp Chiusini Pomolo Fisso
		2 Pezzi 1 Coppia 10 Pezzi 10 Pezzi 2 Pezzi

Fissaggi Pagina 33
ENGLISH

Order specifics	Codes	Standard Packing
For all articles: Article code Wood species code Type of finish for stainless steel Type of fixing	S = Satin finish P = Bright finish	Pull handles Lever handles Dreh-kipp Snib indicators Fixed Knob
		2 Pieces 1 Pair 10 Pieces 10 Pieces 2 Pieces

Fixings Page 33
FRANCAIS

Caractéristiques de la commande	Codes	Emballage standard
Pour tous les articles: Code d'Article Code d'Essence de Bois Code de Finition Acier Inox Type de Fixation	S = Satiné P = Poli	Poignées Béquilles Dreh-kipp Verrous Bouton Fixes
		2 Pièces 1 Paire 10 Pièces 10 Pièces 2 Pièces

Fixation Page 33
DEUTSCH

Bestellangabe	Zusatzcode	Packeinheit zstück
Für alle Artikel: Artikelcode Artikelcode Holzart Artikelcode Stahloberfläche Befestigungsart	S = Fein matt Satinier P = Hochglanz poliert	Stoßgriffe Türdrücker Fenstergriffe Baderosetten Stahloberfläche Türknoopf fest
		2 Stück 1 Paar 10 Stück 10 Stück 2 Stück

Befestigungen Seite 33
ESPAÑOL

Características del pedido	Código	Confección estándar
Para todos los artículos Código artículo Código madera Código acero Tipos de fijación	S = Satinado P = Brillante	Manillones Manillas Dreh-kipp Cierres Pomo Fijos
		2 Piezas 1 Juego 10 Piezas 10 Piezas 2 Piezas

Fijaciones Pagina 33
NEDERLANDS

Besteiddetails	Code	Standaardverpakking
Voor alle artikelen: Artikelcode Code houttype Code afwerking roestvast staal Bevestigingstype	S = mat geborsteld P = blinkend geborsteld	Deurgrepen Deurkrukken Draaikiep WC-Vergrendelingen Hefschuifdeurkruk
		2 Stuks 1 Paar 10 Stuks 10 Stuks 2 Stuks

Bevestiging Pagina 33
ESSENZE - WOOD SPECIES - ESSENCE DE BOIS - HOLZART - MADERA - HOUTTYPE

Art. W1
Frassino
Ash
Frêne
Esche
Ceniza
Es

Art. W2
Mogano
Mahogany
Acajou
Mahagoni
Caoba
Mahonie

Art. W3
Wenge
Wenge
Wenge
Wenge
Wenge
Wenge

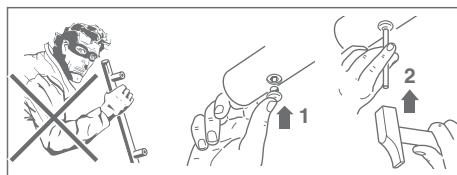
SISTEMA DI FISSAGGIO ANTIEFFRAZIONE PER FISSAGGI "SERIE/D" (BREVETTATO)
ANTI BREAK-IN FIXING SYSTEM FOR FIXING "SERIE/D" (PATENTED)
SYSTÈME DE FIXATION ANTI EFFRACTION POUR FIXATION "SERIE/D" (BREVETE)
BEFESTIGUNGSSET DIEBSTAHSICHER FÜR BEFESTIGUNGEN "SERIE/D" (PATENTIERT)
SISTEMA DE FIJACIÓN ANTISABOTAJE PARA FIJACIONES "SERIE/D" (BREVETADO)
ANTIVANDALISMEBEVESTIGING VOOR BEVESTIGING "SERIE/D" (GEBREVETTEERD)

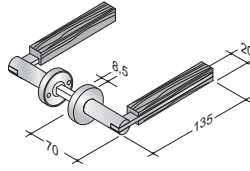

ART.2001.YOD

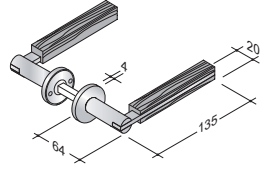

ART.2001.YOD/04

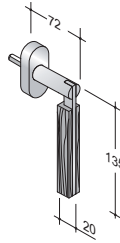

ART.2001.YOD.DK

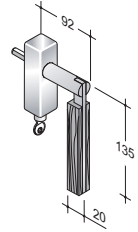

ART.2001.YOD.DK/K

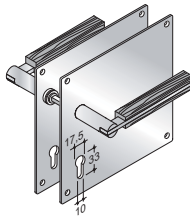

ART.2001.YOD.PLA.Y

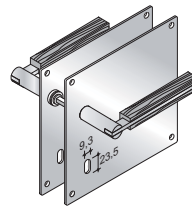

ART.2001.YOD.PLA.P

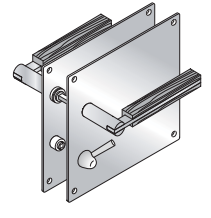

ART.2001.YOD.PLA.CH

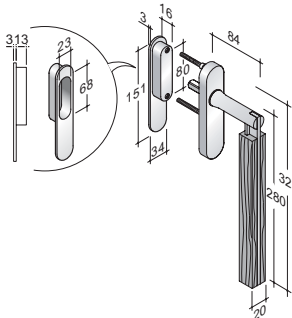

ART.2001.YOD.AS

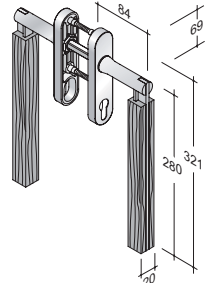

ART.2001.YOD.AS/D

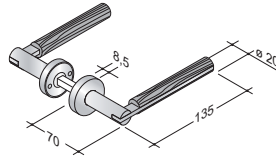

ART.2002.YOD

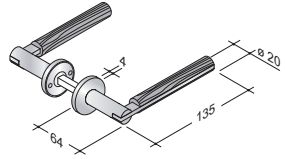

ART.2002.YOD/04

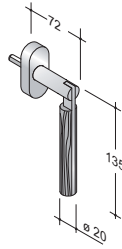

ART.2002.YOD.DK

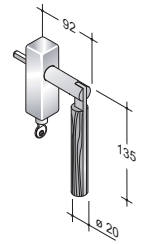

ART.2002.YOD.DK/K

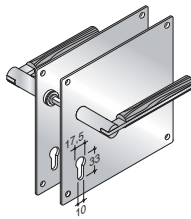

ART.2002.YOD.PLA.Y

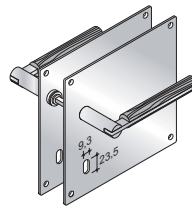

ART.2002.YOD.PLA.P

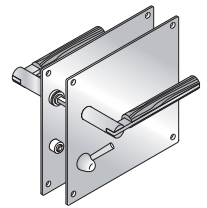

ART.2002.YOD.PLA.CH

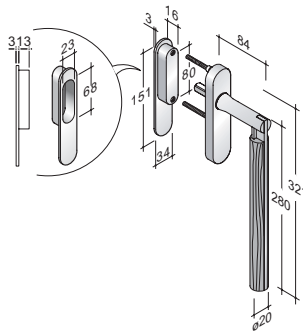

ART.2002.YOD.AS

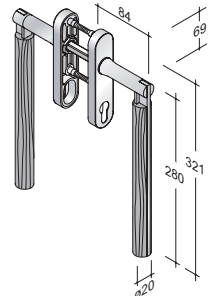

ART.2002.YOD.AS/D

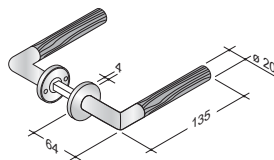
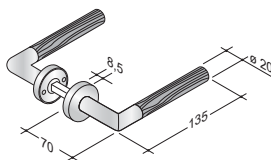

ART.2003.YOD

ART.2003.YOD/04

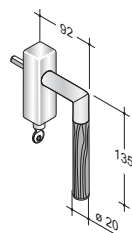
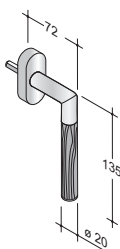

ART.2003.YOD.DK

ART.2003.YOD.DK/K

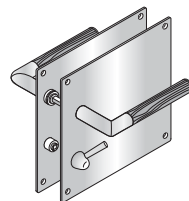
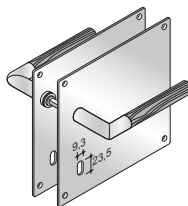
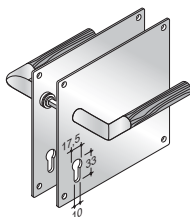

ART.2003.YOD.PLA.Y

ART.2003.YOD.PLA.P

ART.2003.YOD.PLA.CH

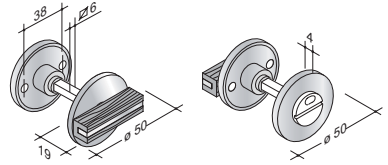

ART.2001.YOD.CH

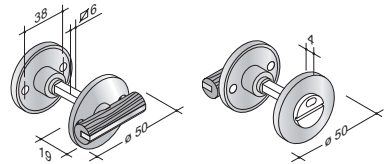
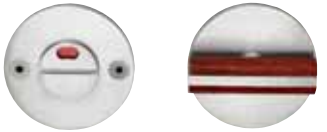

ART.2002.YOD.CH

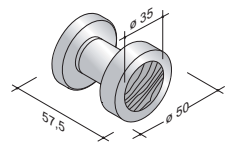

ART.2092.YOD

ART.	A	B	C	D
200.YOD.001	250	280	54	170

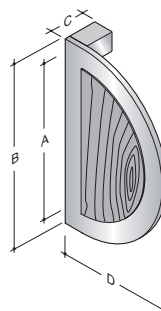

ART.	A	B	C	D
200.YOD.011	250	275	54	162

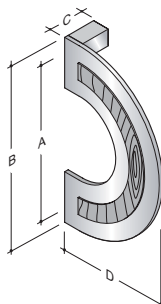

ART.	A	B	C	D
200.YOD.021	250	275	54	162

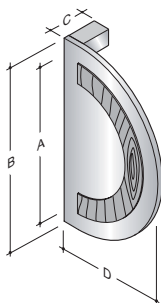

ART.	A	B	C	D
200.YOD.031	250	275	54	230

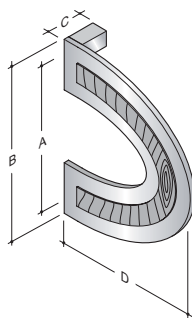

ART.	A	B	C	D
200.YOD.041	250	275	54	230

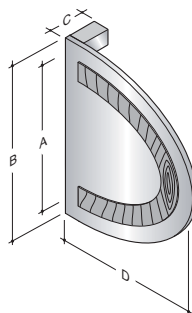



ART.	A	B	C	D
200.YOD.101	250	280	54	170

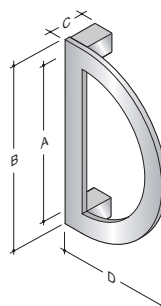

ART.	A	B	C	D
200.YOD.111	250	275	54	162

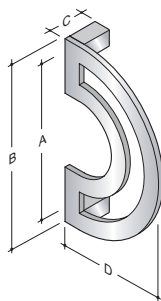

ART.	A	B	C	D
200.YOD.121	250	275	54	162

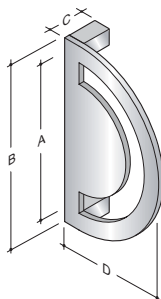

PROGRAMMA YOD

ART.	A	B	C	D
200.YOD.131	250	275	54	230

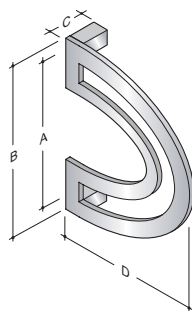

ART.	A	B	C	D
200.YOD.141	250	275	54	230

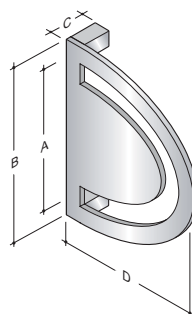

PROGRAMMA YOD

ART.	A	B	D	Ø
200.YOD.201	250	270	65	20
200.YOD.202	350	370	65	20
200.YOD.203	450	475	70	25
200.YOD.204	550	575	70	25

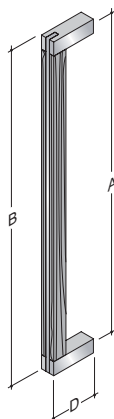

ART.	A	B	D	Ø
200.YOD.211	250	400	65	20
200.YOD.212	350	500	65	20
200.YOD.213	450	600	70	25
200.YOD.214	550	700	70	25

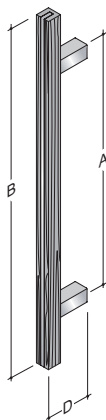

PROGRAMMA YOD

ART.	A	B	D	Ø
200.YOD.301	200	220	60	20
200.YOD.302	300	320	60	20
200.YOD.303	350	375	60	25
200.YOD.304	450	475	60	25

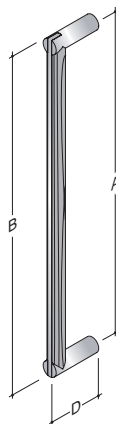

ART.	A	B	D	Ø
200.YOD.311	200	350	65	20
200.YOD.312	300	450	65	20
200.YOD.313	350	500	70	25
200.YOD.314	450	600	70	25

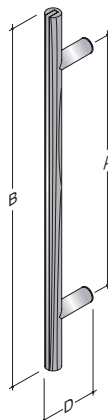

PROGRAMMA YOD

ART.	A	B	L1	D	Ø
200.YOD.401	250	400	100	65	20
200.YOD.402	350	500	100	65	20
200.YOD.403	350	500	110	70	25
200.YOD.404	450	600	110	70	25
200.YOD.405	450	600	120	75	30
200.YOD.406	550	700	120	75	30
200.YOD.407	550	700	130	80	35
200.YOD.408	750	900	130	80	35

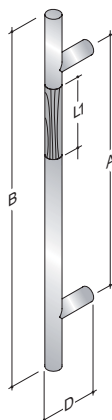

ART.	A	B	L1	D	Ø
200.YOD.411	350	500	110	75	25
200.YOD.412	450	600	110	75	25
200.YOD.413	450	600	120	75	30
200.YOD.414	550	700	120	75	30

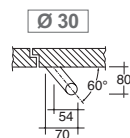
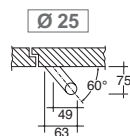
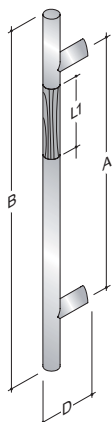

FISSAGGI SERIE /D
FIXINGS SERIES /D
FIXATIONS SERIE /D

BEFESTIGUNGEN SERIE /D
FIJACIONES SERIE /D
BEVESTIGING SERIE /D

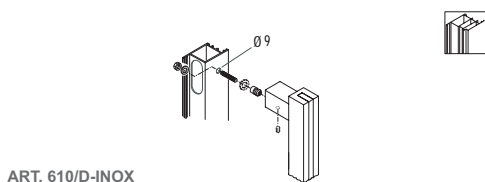

ART. 610/D-INOX

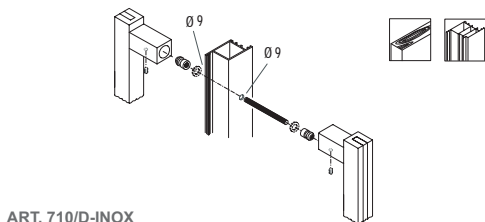

ART. 710/D-INOX

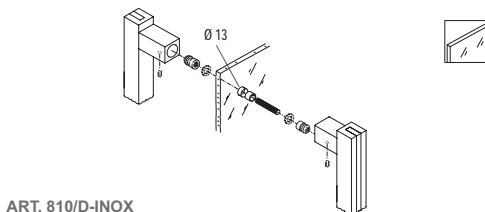

ART. 810/D-INOX

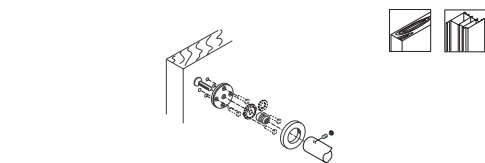

ART. 911/D-912/D-913/D-914/D-INOX

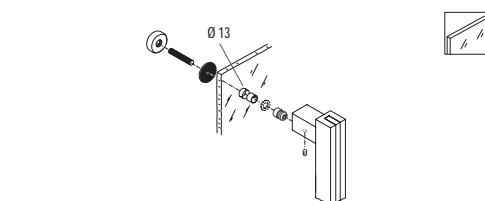

ART. 1011/D-1012/D-1013/D-1014/D-INOX

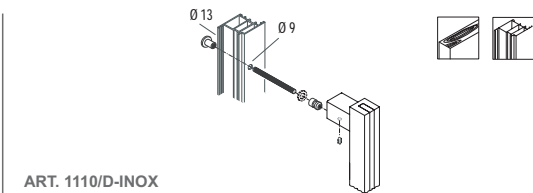

ART. 1110/D-INOX

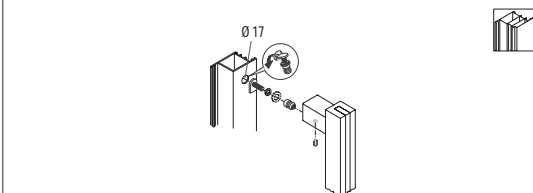

ART. 1210/D-INOX

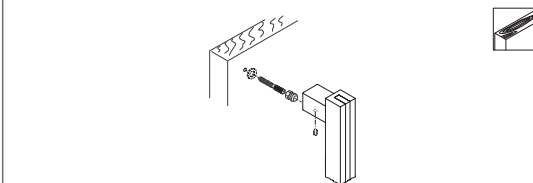

ART. 1310/D-INOX

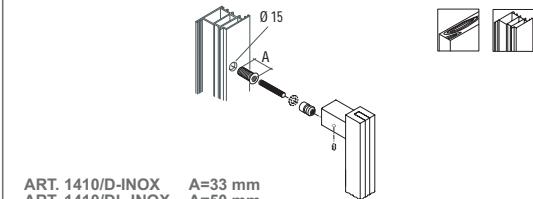

ART. 1410/D-INOX A=33 mm
ART. 1410/DL-INOX A=50 mm

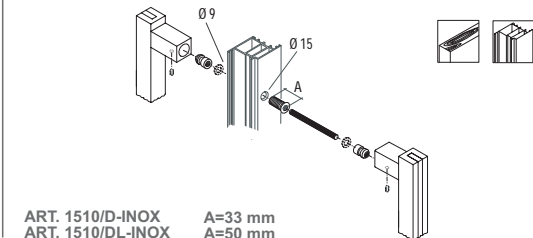

ART. 1510/D-INOX A=33 mm
ART. 1510/DL-INOX A=50 mm

LEGENDA - KEY TO SYMBOL - LÉGENDE - ZEICHENERKLÄRUNG - LEYENDA - LEGENDE

Legno
Wood
Holz
Bois
Madera
Hout

Alluminio / Pvc
Aluminium / Pvc
Aluminium / Pvc
Aluminium / Pvc
Aluminium / Pvc

Vetro
Glass
Verre
Glass
Cristal
Glass
Spessori per protezione vetro in dotazione
Glass protections included
Protections pour verre incluses
Schutzteilen für Glas im Lieferumfang enthalten
Juntas de protección para cristal incluidas
Glasbeschermingsrubbers meegeleverd in de verpakking

PROGRAMMA 2000

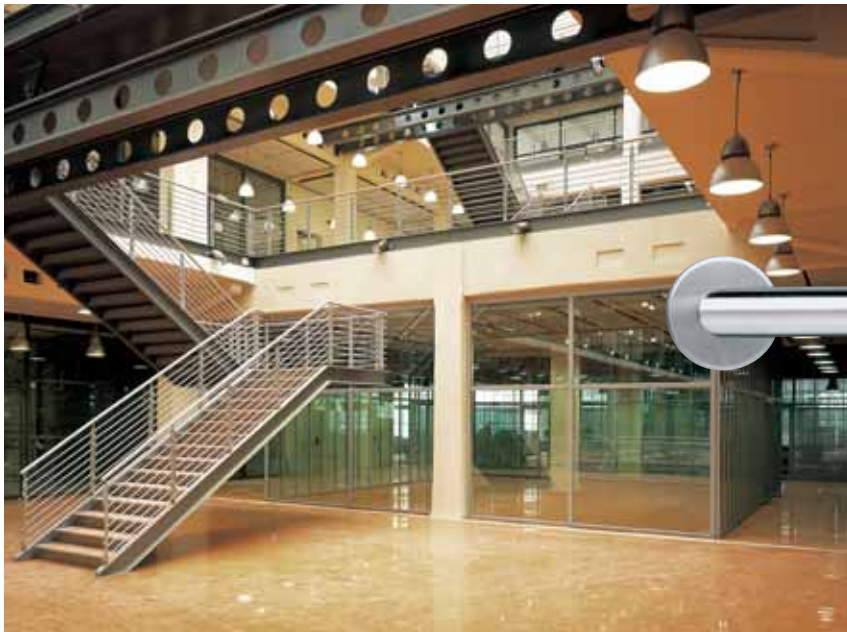

PHOTO: Gabriele Basilio

ITALIANO

PROGRAMMA 2000
 Maniglie, pomoli, martelline e complementi in acciaio inox AISI 316L.
 Rigorosamente made in Italy.
 Finitura standard: satinata.
 Finitura a richiesta: lucida.

ENGLISH

PROGRAMMA 2000
 Lever handles, knobs, window handles and accessories in stainless steel AISI 316L.
 Precision manufactured in Italy.
 Standard finishing: satin.
 Finishing by request: bright.

FRANCAIS

PROGRAMMA 2000
 Bequilles, boutons, béquilles pour fenêtres et accessoires de finition en acier inoxydable AISI 316L.
 Exclusivement made in Italy.
 Finition standard: satinée
 Finition sur demande: polie.

DEUTSCH

PROGRAMMA 2000
 Türdrücker, Türknoöpfen, Fenstergriffen und Baubeschläge aus Edelstahl rostfrei 1.4404 Made in Italy.
 Standardausführung: Matt satiniert.
 Hochglanz polierte Ausführung auf Anfrage lieferbar.

ESPAÑOL

PROGRAMMA 2000
 Manillas, pomos, dreh-kipp y complementos en acero inoxidable AISI 316L.
 Rigurosamente hecho en Italia.
 Acabados en serie: satinado.
 Acabados bajo petición: brillante.

NEDERLANDS

PROGRAMMA 2000
 Deurkrukken, deurknoppen, raamgrepen en accessoires in roestvast staal AISI 316L.
 Uitsluitend gefabriceerd in Italië.
 Standaardafwerking: mat geborsteld.
 Afwerking op aanvraag: blinkend gepolijst.

ITALIANO

Specifiche d'ordine	Codici	Confezioni standard	
Per tutti gli articoli: Codice articolo	S= Satinato	Maniglia Maniglia	10 Coppie
Tipologia di finitura	P= Lucido	FS DIN 18 273	1 Coppia
Verso destro o sinistro		Pomoli Fissi	2 Pezzi
		Pomoli Girevoli	1 Coppia
Per le placche: Disegno quotato		Alzante scorrevole	1 Coppia
		Combinazioni	1 Coppia
		Maniglia su placca	1 Coppia
		Maniglia fissa	
Per maniglie tagliafuoco: Specificare lo spessore della porta		su placca	2 Pezzi
		Dreh-kipp	10 Pezzi
		Bocchette	10 Coppie
		Fermaporte	10 Pezzi
		Appendiabiti	10 Pezzi
		Pittogramma	1 Pezzo
		Numeri e lettere	1 Pezzo
		Chiusini	10 Pezzi

Fissaggi
Pagina 65
ENGLISH

Order specifics	Codes	Standard Packing	
For all articles: Article code	S= Satin finish	Handles Handles	10 Pairs
Type of finish	P= Bright finish	FS DIN 18 273	1 Pair
Right or left version		Fixed knobs	2 Pieces
		Turning knobs	1 Pair
For plates: Quoted design		Sliding lift-up	1 Pair
		Combinations	1 Pair
		Handle on plate	1 Pair
		Fixed handle on plate	2 Pieces
For fireproof lever handles: Specify the door thickness		Dreh-kipp	10 Pieces
		Escutcheons	10 Pairs
		Door stops	10 Pieces
		Clothes hooks	10 Pieces
		Pictogram	1 Piece
		Numbers and letters	1 Piece
		Snib indicators	10 Pieces

Fixings
Page 65
FRANCAIS

Caractéristiques de la commande	Codes	Emballage standard	
Pour tous les articles: Code article	S= Satiné	Bequilles Bequilles	10 Paires
Typologie de finition	P= Poli	FS DIN 18 273	1 Paire
Versión droite ou gauche		Boutons fixes	2 Pièces
		Boutons tournants	1 Paire
		Montant coulissant	1 Paire
Pour les plaques: Dessin avec les cotés		Combinaisons	1 Paire
		Bequilles sur plaque	1 Paire
		Bequilles fixe sur plaque	2 Pièces
Pour bÉquilles pour portes coupe feu et coupe fumÉe: SpÉcifier l'Épaisseur de la porte		Béquilles	10 Pièces
		Entrées	10 Paires
		Arrêt de porte	10 Pièces
		Porte-manteaux	10 Pièces
		Pictogramme	1 Pièce
		Chiffres et lettres	1 Pièce
		Verrous	10 Pièces

Fixation
Page 65
DEUTSCH

Bestellangabe	Zusatzcode	Packeneinheit	
Für alle Artikel: Artikelnummer	S= fein matt saniert	Zimmer_rdr_cker Feuerschutzgarnitur	10 Paar 1Paar
Ausführung		T_rknopf fest	2 Stück
Montage links oder rechts	P= hochglanz poliert	T_rknopf drehbar Griff f_r Schiebet_r	1 Paar 1 Paar
Für die Türschilder: Maßangabe gemäß Zeichnung		Wechselgarnitur Dr_cker mit T_rschilder Griff fest auf T_rschilder	1 Paar 2 Stück
Feuerschutzgarnituren: Türstärke		Fenstergriff Schl_sselrosette T_rstopper Kleiderhaken Piktogramm Ziffer und Buchstabe Baderosetten	10 Stück 10 Paar 10 Stück 10 Stück 1 Stück 1 Stück 10 Stück

Befestigungen
Seite 65
ESPAÑOL

Características del pedido	Código	Confección estándar	
Para todos los artículos: Código artículo	S= Satinado	Manillas Manillas	10 Juegos
Tipo de acabado	P= Brillante	FS DIN 18 273	1 Juego
Montaje derecha o izquierda		Pomos fijos	2 Piezas
		Pomos mÓviles	1 Juego
Para las placas: Dibujo acotado		Manilla para correderas elevables	1 Juego
		Combinaciones	1 Juego
		Manilla placa	1 Juego
Para manillas cortafuegos: Especificar el grosor de puerta		Manilla fija placa Drehkipp	2 Piezas 10 Piezas
		Bocallave	10 Juegos
		Tope de puerta	10 Piezas
		Colgador	10 Piezas
		Pictograma	1 Pieza
		Nºmeros y letras	1 Pieza
		Cierres	10 Piezas

FijaciÓnes
Página 65
NEDERLANDS

Bestelgegevens	Code	Standaardverpakking	
Voor alle artikelen: Artikelcode	S= mat geborsteld	Krukken Krukken	10 Paar
Afwerkingstype		FS DIN 18 273	1 Paar
Links-of Rechtszijdend	P= blinkend geborsteld	Hefschuifdeurkruk Knop-krukcombinatie	1 Paar 1 Paar
Voor de platen: Goedgekeurde tekening		Kruk op schild Kruk vast op schild	1 Paar 2 Stuks
Voor deurkrukken voor brandwerende deuren: Deurdikte opgeven		Draaikiep Sleutelrozetten Deurstop Kapstok Pictogram Cijfers en letters WC vergrendelingen	10 Stuks 10 Stuks 10 Paar 10 Stuks 1 Stuk 1 Stuk 10 Stuks

Befestiging
Página 65
LEGENDA - KEY TO SYMBOL - L...GENDE - ZEICHENERKLÄRUNG - LEYENDA - LEGENDE

Con molla di ritorno.
With return spring.
Avec ressort de rappel.
Mit Rückholfeder kombinieren.
Con muelle de retorno.
Met veersysteem.

DIN 18 273



Norma DIN 18 273.
Comply with DIN 18 273.
Conformes à DIN 18 273.
DIN 18 273 kombinieren.
Normas DIN 18 273.
Volgens DIN 18 273.



Certificazione norma DIN 18 273.
DIN 18 273 certified.
Certification norme DIN 18 273.
DIN 18 273 Zertifiziert.
Certificación norma DIN 18 273.
Certificaten norm DIN 18 273.

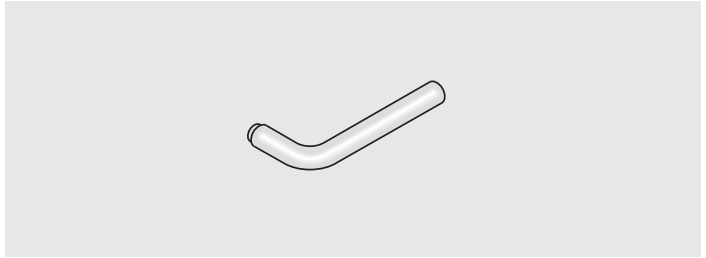

Con cuscinetto.
With ball-bearing.
Avec roulement.
Mit Kugellager kombinieren.
Con rodamiento de bolas.
Met kogellagering.



Ø 16

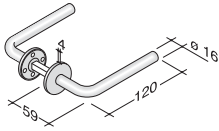

ART. 2016T/04

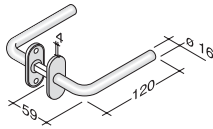

ART. 2016/04

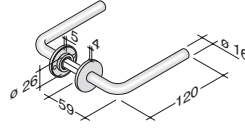

ART. 2016T/CS/04

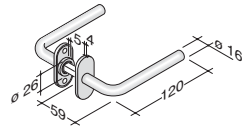

ART. 2016/CS/04

Ø 20

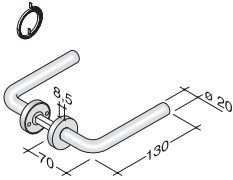

ART. 2028T

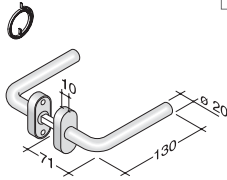

ART. 2028

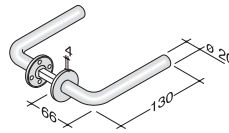

ART. 2028T/04

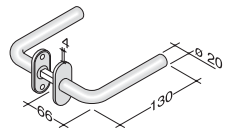

ART. 2028/04

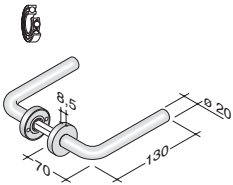

ART. 2028T/CS

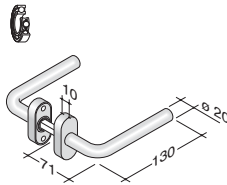

ART. 2028/CS

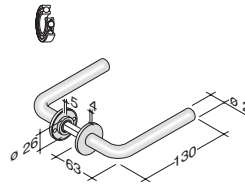

ART. 2028T/CS/04

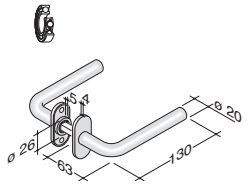

ART. 2028/CS/04

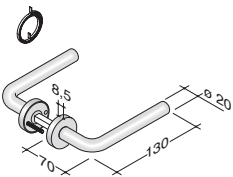

ART. 2028T/CO

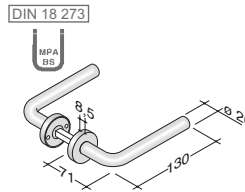

ART. 2028T/FS

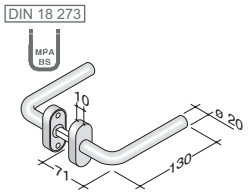

ART. 2028/FS



Ø 16

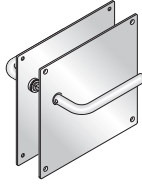

ART. 2016/2001

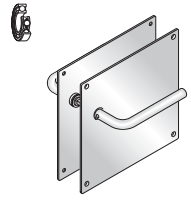

ART. 2016/2001/CS

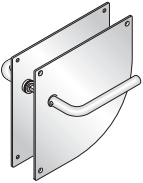

ART. 2016/2051

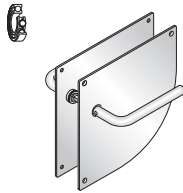

ART. 2016/2051/CS

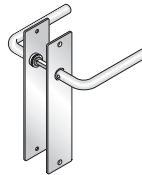

ART. 2016/2101



ART. 2016/2101/CS

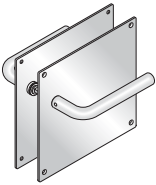

ART. 2028/2001

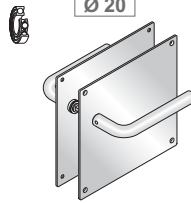

ART. 2028/2001/CS

DIN 18 273

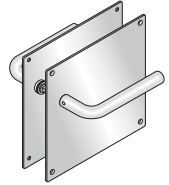

ART. 2028/2001/FS

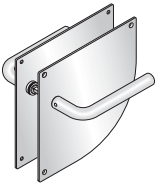

ART. 2028/2051

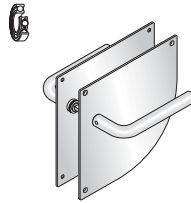

ART. 2028/2051/CS

DIN 18 273

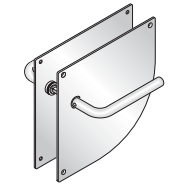

ART. 2028/2051/FS



ART. 2028/2101



ART. 2028/2101/CS

DIN 18 273



ART. 2028/2101/FS

Disponibili anche con:
Available also with:
Disponible même avec:
Verfügbar auch mit:
Disponibles también:
Ook beschikbaar met:

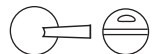
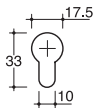

Ø 16

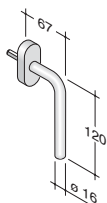

ART. 2016DK

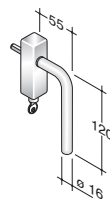

ART. 2016DK/K

Ø 20

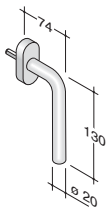

ART. 2028DK

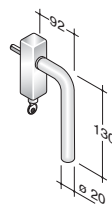

ART. 2028DK/K

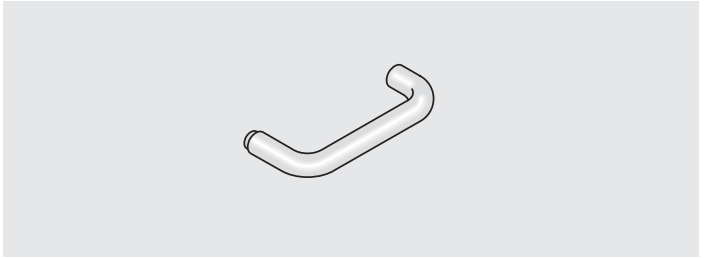

Ø 16

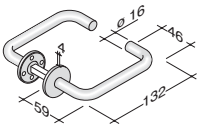

ART. 2016BT/04

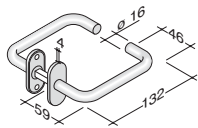

ART. 2016B/04

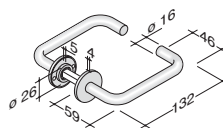

ART. 2016BT/CS/04

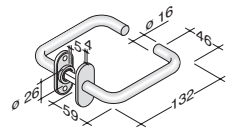

ART. 2016B/CS/04

Ø 20

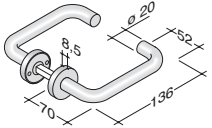

ART. 2028BT

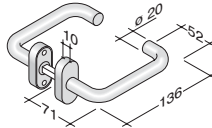

ART. 2028B

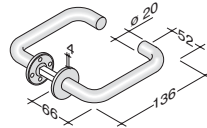

ART. 2028BT/04

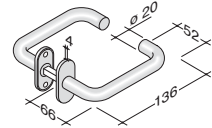

ART. 2028B/04

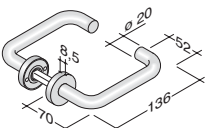

ART. 2028BT/CS

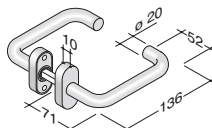

ART. 2028B/CS

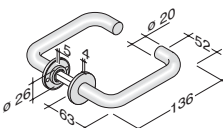

ART. 2028BT/CS/04

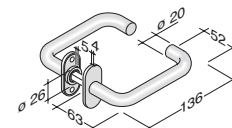

ART. 2028B/CS/04



DIN 18 273

DIN 18 273

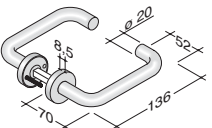

ART. 2028BT/CO

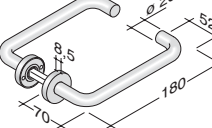

ART. 2028BT/CS/H

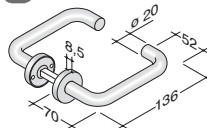

ART. 2028BT/FS

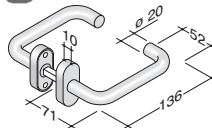

ART. 2028B/FS

PROGRAMMA 2000

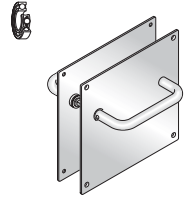
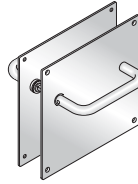
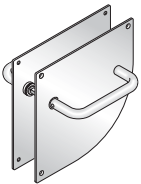
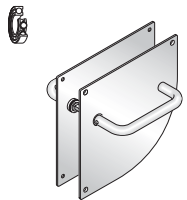
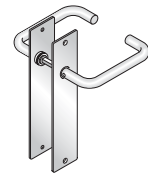
Ø 16

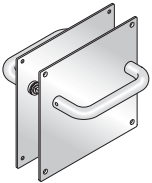
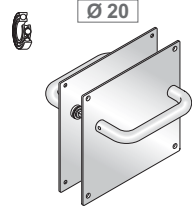
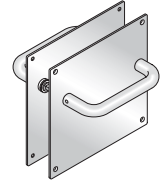
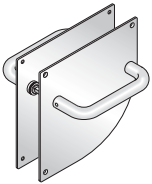
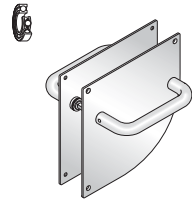
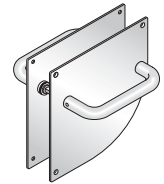
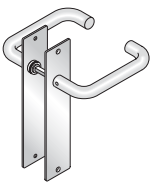
ART. 2016B/2001
ART. 2016B/2001/CS

ART. 2016B/2051

ART. 2016B/2051/CS

ART. 2016B/2101

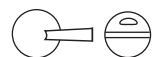
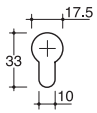
ART. 2016B/2101/CS

ART. 2028B/2001

ART. 2028B/2001/CS

ART. 2028B/2001/FS
DIN 18 273

ART. 2028B/2051

ART. 2028B/2051/CS

ART. 2028B/2051/FS
DIN 18 273

ART. 2028B/2101

ART. 2028B/2101/CS

ART. 2028B/2101/FS
DIN 18 273



Disponibili anche con:
 Available also with:
 Disponible même avec:
 Verfügbar auch mit:
 Disponibles también:
 Ook beschikbaar met:

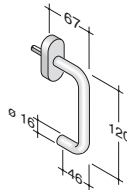

Ø 16

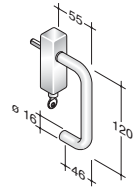

ART. 2016BDK



ART. 2016BDK/K

Ø 20

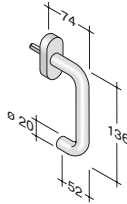

ART. 2028BDK

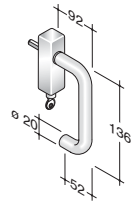

ART. 2028BDK/K

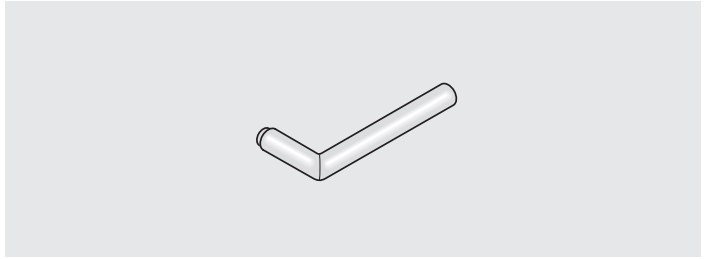

Ø 16

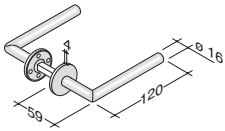

ART. 2016LT/04

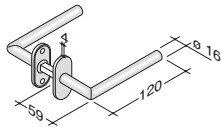

ART. 2016L/04

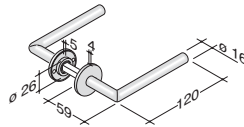

ART. 2016LT/CS/04

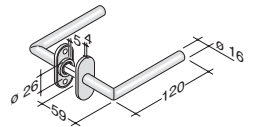

ART. 2016L/CS/04

Ø 20

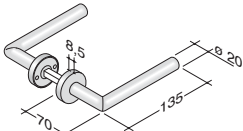

ART. 2030T

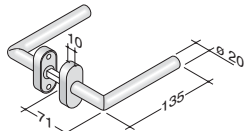

ART. 2030

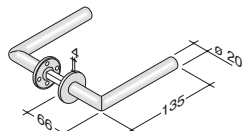

ART. 2030T/04

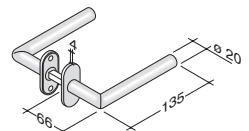

ART. 2030/04

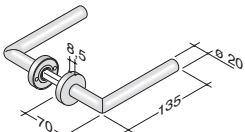

ART. 2030T/CS

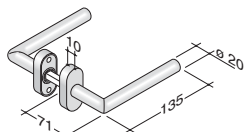

ART. 2030/CS

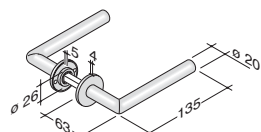

ART. 2030T/CS/04

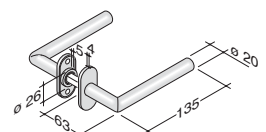

ART. 2030/CS/04



DIN 18 273



DIN 18 273

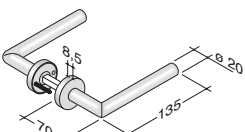

ART. 2030T/CO

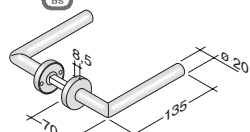

ART. 2030T/FS

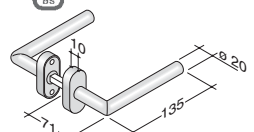

ART. 2030/FS

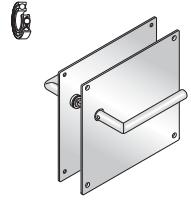
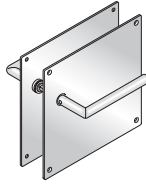
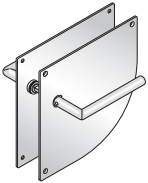
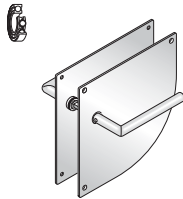
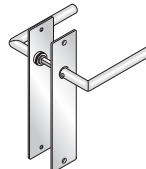
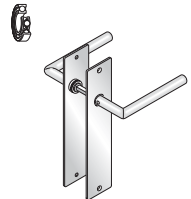
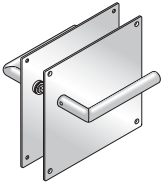
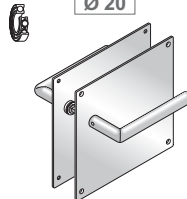
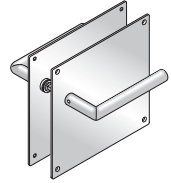
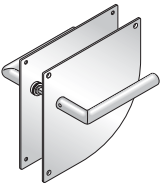
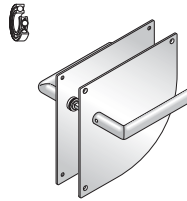
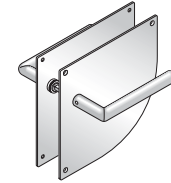
PROGRAMMA 2000
Ø 16

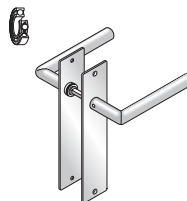
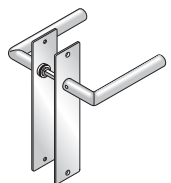
ART. 2016L/2001
ART. 2016L/2001/CS

ART. 2016L/2051

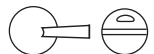
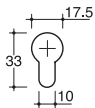
ART. 2016L/2051/CS

ART. 2016L/2101

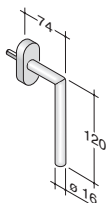
ART. 2016L/2101/CS
Ø 20
DIN 18 273

ART. 2030/2001

ART. 2030/2001/CS

ART. 2030/2001/FS

ART. 2030/2051

ART. 2030/2051/CS

ART. 2030/2051/FS

ART. 2030/2101

ART. 2030/2101/CS

ART. 2030/2101/FS

Disponibili anche con:
Available also with:
Disponible même avec:
Verfügbar auch mit:
Disponibles también:
Ook beschikbaar met:



Ø 16



ART. 2016LDK

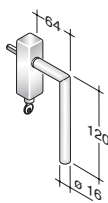

ART. 2016LDK/K

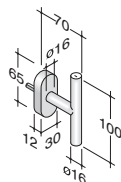

ART. 2016DK/001

Ø 20

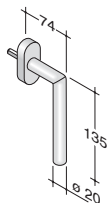

ART. 2030DK

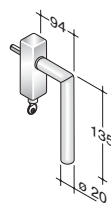

ART. 2030DK/K

Ø 16

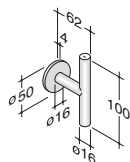

ART. 2016/002

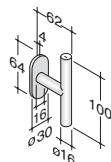

ART. 2016/003

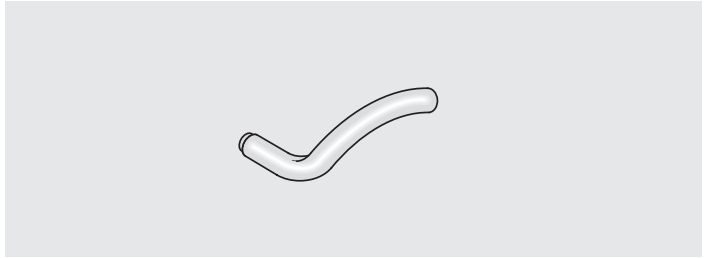

Ø 20

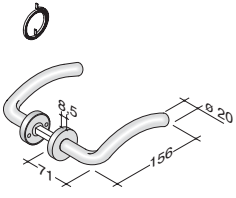

ART. 2026T

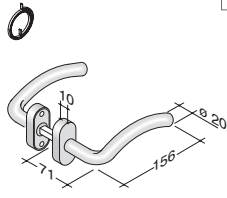

ART. 2026

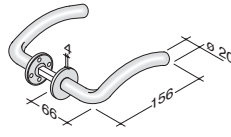

ART. 2026T/04

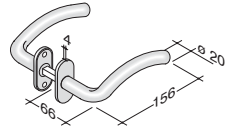

ART. 2026/04

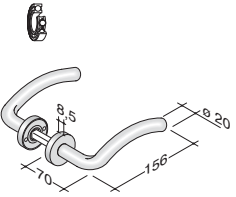

ART. 2026T/CS

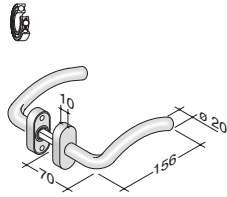

ART. 2026/CS

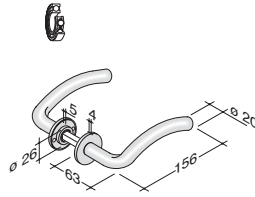

ART. 2026T/CS/04

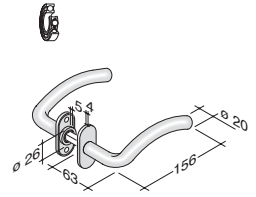

ART. 2026/CS/04

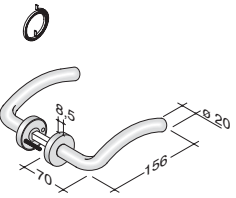

ART. 2026T/CO

DIN 18 273

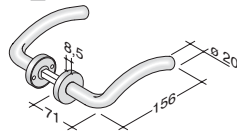

ART. 2026T/FS

DIN 18 273

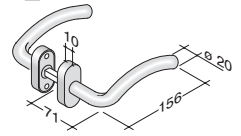

ART. 2026/FS

Ø 20

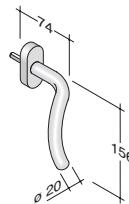

ART. 2026DK

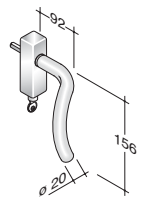

ART. 2026DK/K

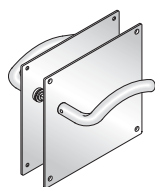

ART. 2026/2001

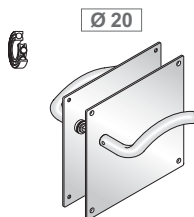

ART. 2026/2001/CS

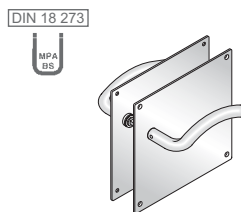

ART. 2026/2001/FS

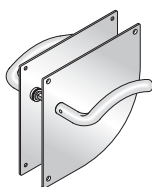

ART. 2026/2051

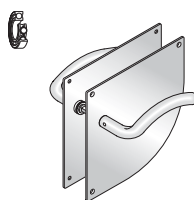

ART. 2026/2051/CS

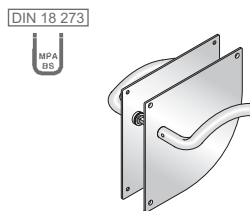

ART. 2026/2051/FS



ART. 2026/2101

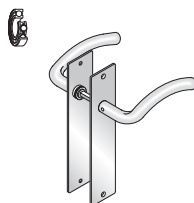

ART. 2026/2101/CS

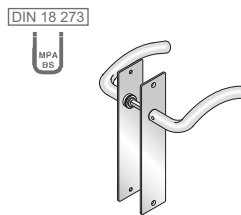

ART. 2026/2101/FS

Disponibili anche con:
 Available also with:
 Disponible même avec:
 Verfügar auch mit:
 Disponibles también:
 Ook beschikbaar met:

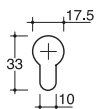

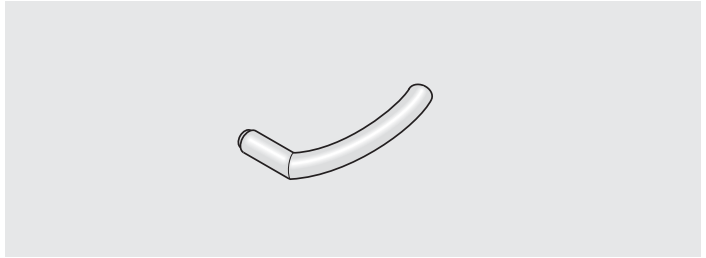

Ø 20

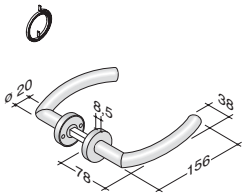

ART. 2027T

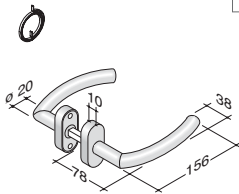

ART. 2027

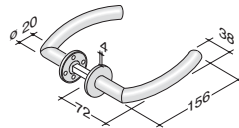

ART. 2027T/04

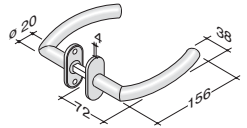

ART. 2027/04

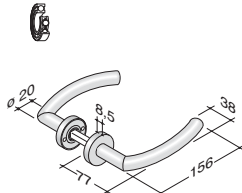

ART. 2027T/CS

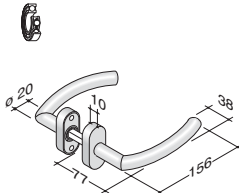

ART. 2027/CS

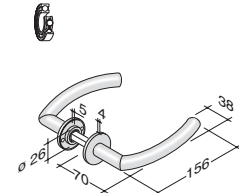

ART. 2027T/CS/04

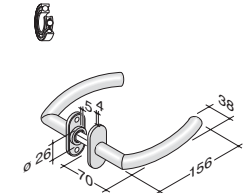

ART. 2027/CS/04

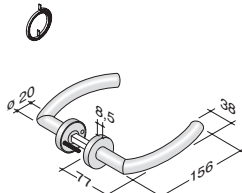

ART. 2027T/CO

Ø 20

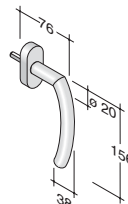

ART. 2027DK

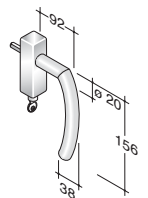

ART. 2027DK/K



Ø 20

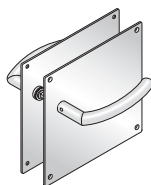

ART. 2027/2001

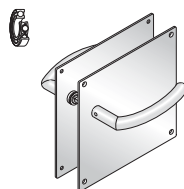

ART. 2027/2001/CS

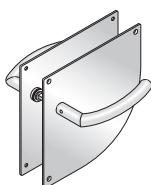

ART. 2027/2051

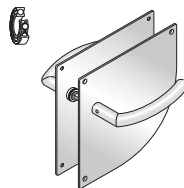

ART. 2027/2051/CS

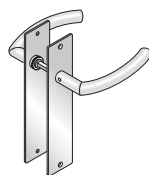

ART. 2027/2101

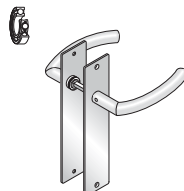

ART. 2027/2101/CS

Disponibili anche con:
Available also with:
Disponible même avec:
Verfügbar auch mit:
Disponibles también:
Ook beschikbaar met:

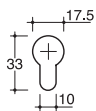

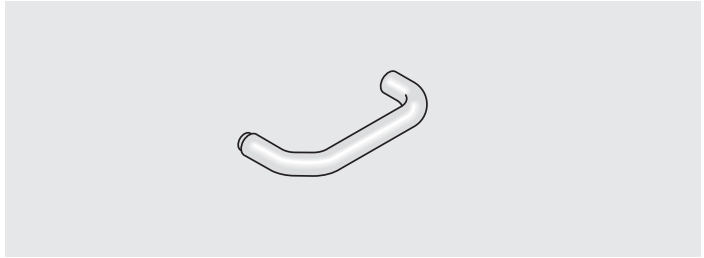

Ø 20

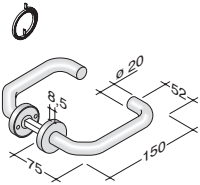

ART. 2029T

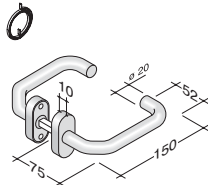

ART. 2029

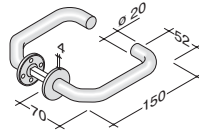

ART. 2029T/04

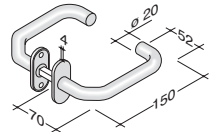

ART. 2029/04

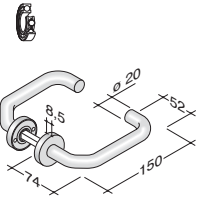

ART. 2029T/CS

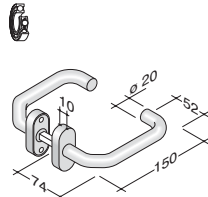

ART. 2029/CS

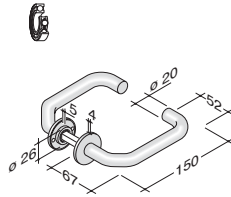

ART. 2029T/CS/04

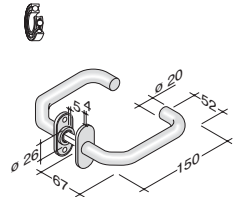

ART. 2029/CS/04

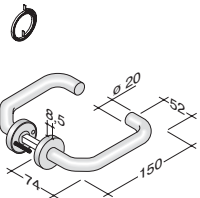

ART. 2029T/CO

DIN 18 273

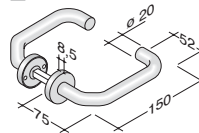

ART. 2029T/FS

DIN 18 273

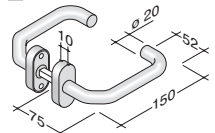

ART. 2029/FS

Ø 20

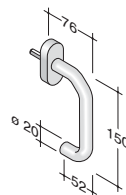

ART. 2029DK

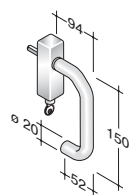

ART. 2029DK/K

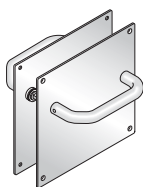
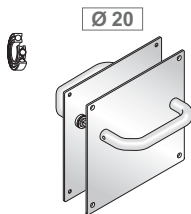
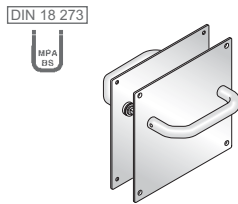
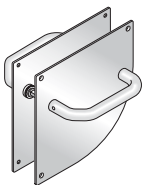
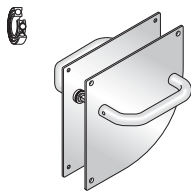
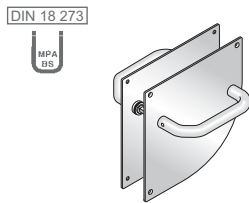
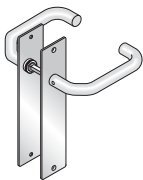
ART. 2029/2001

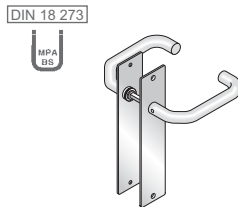
ART. 2029/2001/CS

ART. 2029/2001/FS

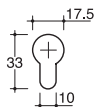
ART. 2029/2051

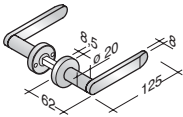
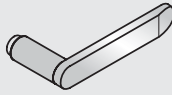
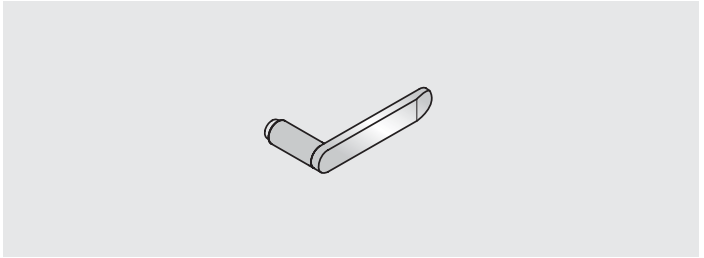
ART. 2029/2051/CS

ART. 2029/2051/FS

ART. 2029/2101

ART. 2029/2101/CS

ART. 2029/2101/FS

Disponibili anche con:
 Available also with:
 Disponible même avec:
 Verfügbar auch mit:
 Disponibles también:
 Ook beschikbaar met:



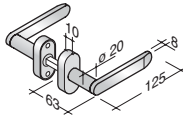

ART. 2020T



ART. 2020

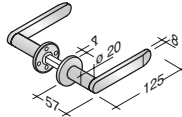

ART. 2020T/04

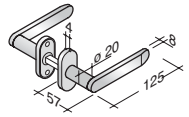

ART. 2020/04

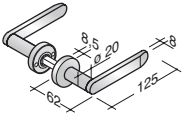

ART. 2020T/CS

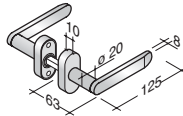

ART. 2020/CS

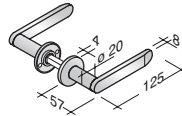

ART. 2020T/CS/04

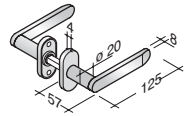

ART. 2020/CS/04

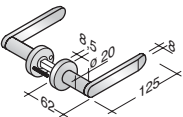

ART. 2020T/CO

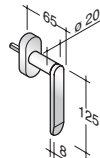

ART. 2020DK

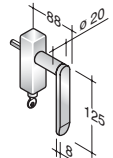

ART. 2020DK/K

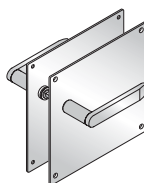

ART. 2020/2001

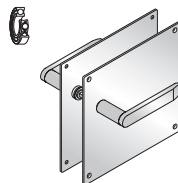

ART. 2020/2001/CS

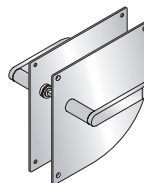

ART. 2020/2051

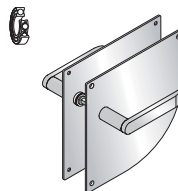

ART. 2020/2051/CS

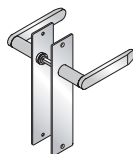

ART. 2020/2101

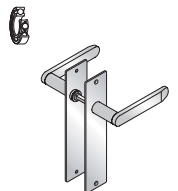

ART. 2020/2101/CS

Disponibili anche con:
 Available also with:
 Disponible m'Áme avec:
 Verf gbar auch mit:
 Disponibles tambi'Qn:
 Ook beschikbaar met:

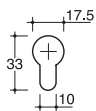

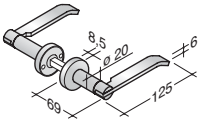
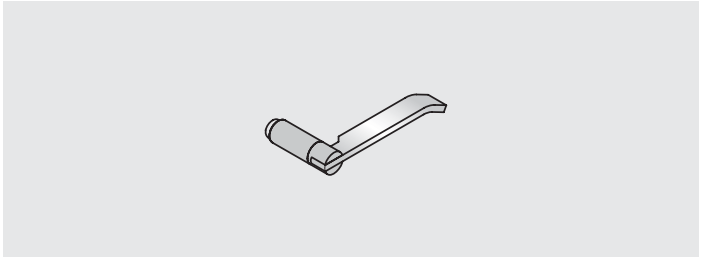

ART. 2022T

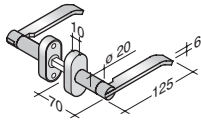

ART. 2022

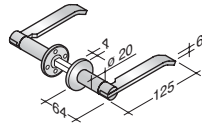

ART. 2022T/04

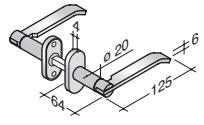

ART. 2022/04

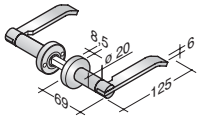

ART. 2022T/CS

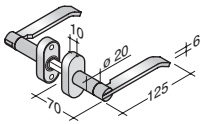

ART. 2022/CS

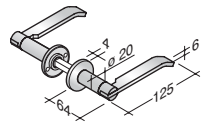

ART. 2022T/CS/04

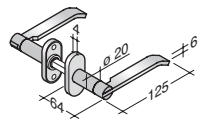

ART. 2022/CS/04

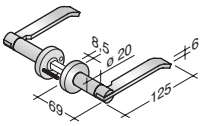

ART. 2022T/CO

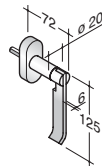

ART. 2022DK

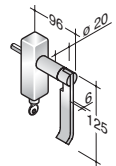

ART. 2022DK/K

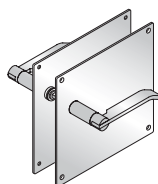

ART. 2022/2001

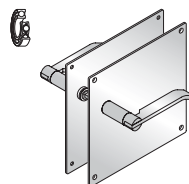

ART. 2022/2001/CS

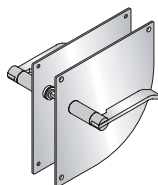

ART. 2022/2051

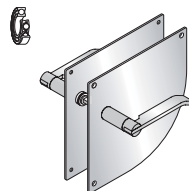

ART. 2022/2051/CS

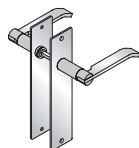

ART. 2022/2101



ART. 2022/2101/CS

Disponibili anche con:
 Available also with:
 Disponible m'Áme avec:
 Verf gbar auch mit:
 Disponibles tambi'En:
 Ook beschikbaar met:

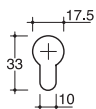

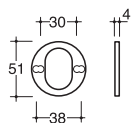
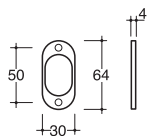
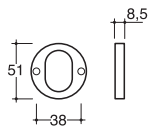
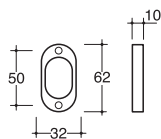
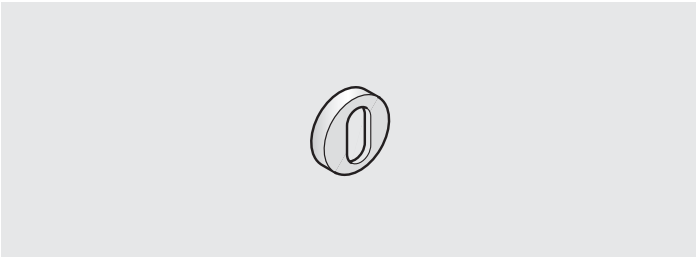

ART. 28BL



ART. 28TBL



ART. 28BL/04



ART. 28TBL/04



ART. 28Y



ART. 28TY



ART. 28Y/04



ART. 28TY/04

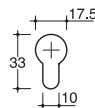

ART. 28P



ART. 28TP



ART. 28P/04



ART. 28TP/04



ART. 28C



ART. 28TC



ART. 28C/04



ART. 28TC/04



ART. 28U



ART. 28TU



ART. 28U/04



ART. 28TU/04



DIN 18 273



ART. 28Y/FS



ART. 28TY/FS

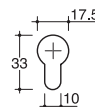

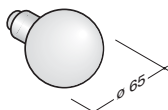
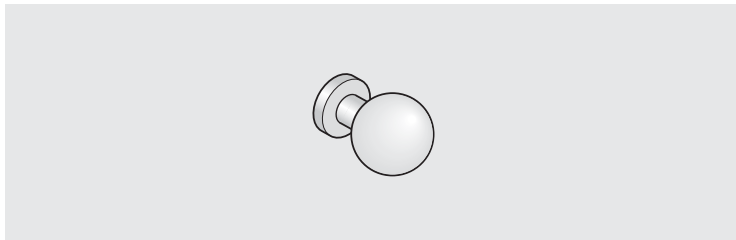

ART. 2090

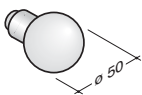

ART. 2091

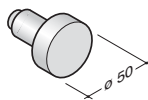

ART. 2092

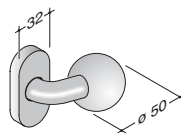

ART. 2093

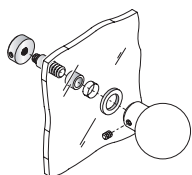

ART. 290/A

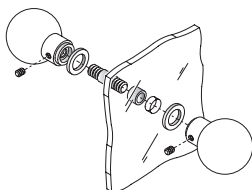

ART. 290/B

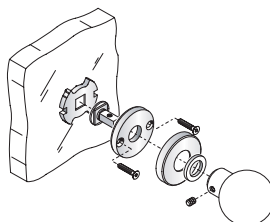

ART. 290/C

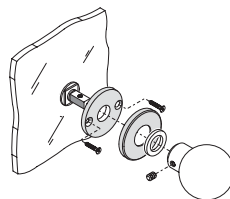

ART. 290/C/04

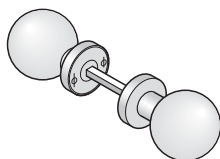

ART. 2090/G

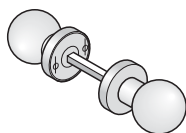

ART. 2091/G

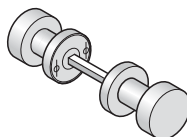

ART. 2092/G

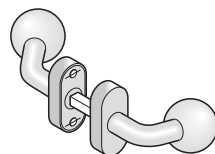

ART. 2093/G

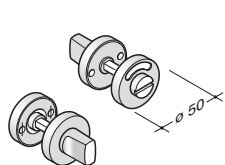
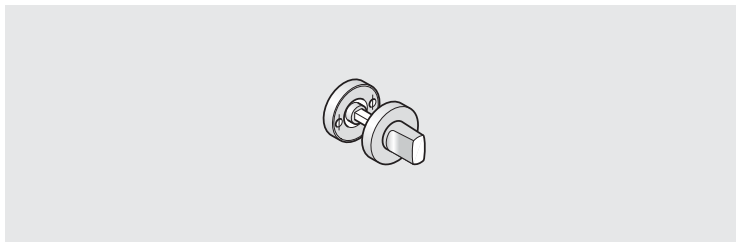

ART. 2032

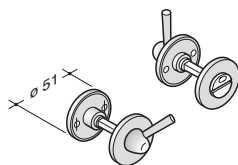

ART. 2033

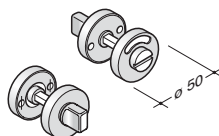

ART. 2034

- 5 - 6
- 6 - 7
- 6 - 8

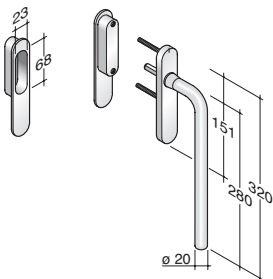
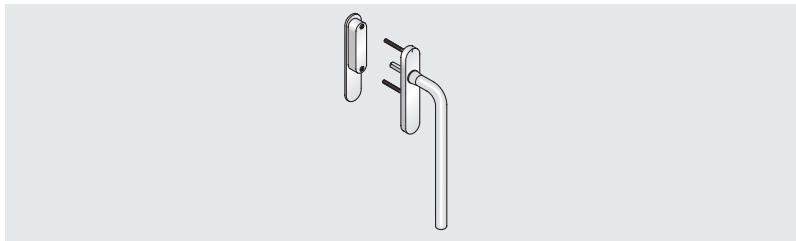

ART. 2045

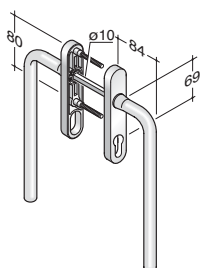

ART. 2045/D

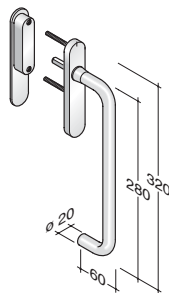

ART. 2046

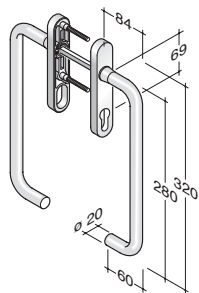

ART. 2046/D

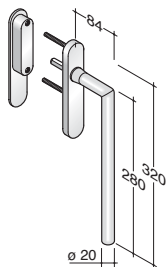

ART. 2047

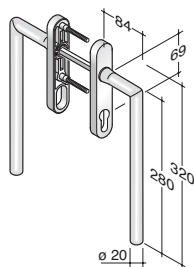

ART. 2047/D

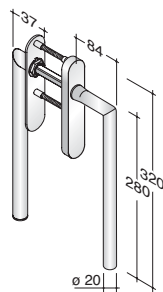

ART. 2047/D/RIB

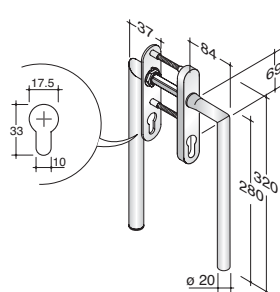

ART. 2047/D/RIB.Y

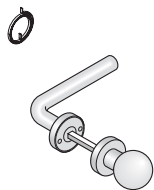
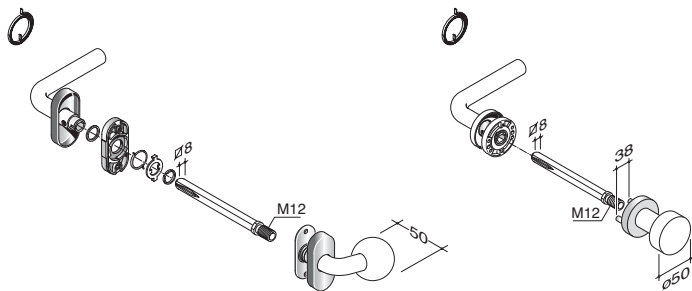
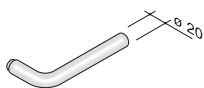
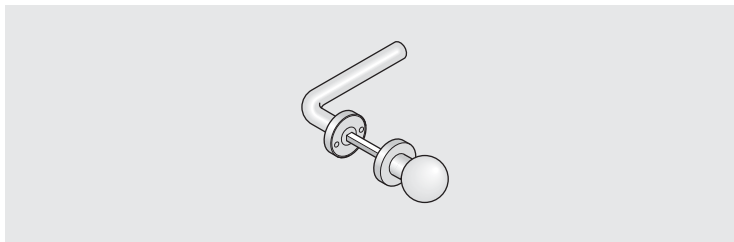

ART. 2500/G

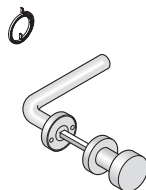

ART. 2510/G

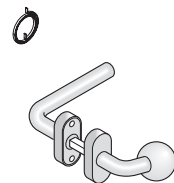

ART. 2530/G

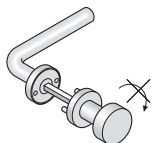

ART. 2510/F

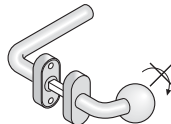

ART. 2530/F

Disponibili anche con:
Available also with:
Disponible même avec:
Verfügbar auch mit:
Disponibles también:
Ook beschikbaar met:

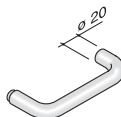
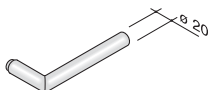

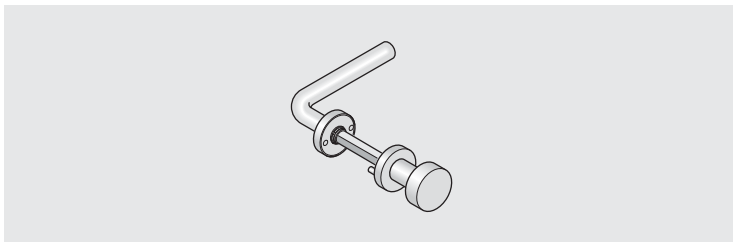

DIN 18 273

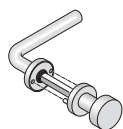
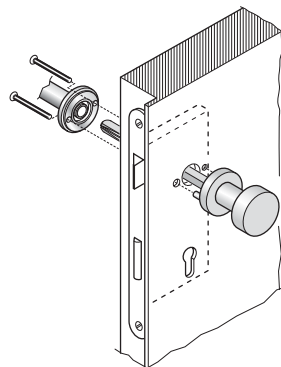
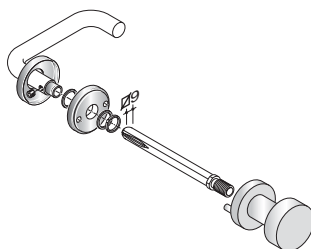

ART. 2510/F/FS

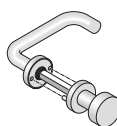

ART. 2511/F/FS

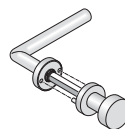

ART. 2513/F/FS

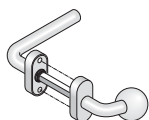
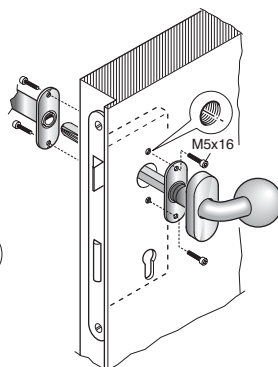
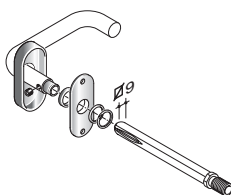

ART. 2530/F/FS



ART. 2531/F/FS

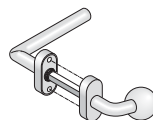

ART. 2533/F/FS

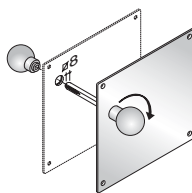
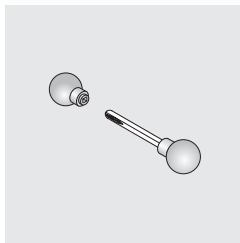

ART. 2091/2001/G

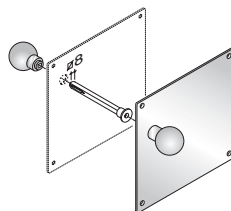

ART. 2091/2001/F

Disponibili anche con:
Available also with:
Disponible même avec:
Verfügbar auch mit:
Disponibles también:
Ook beschikbaar met:

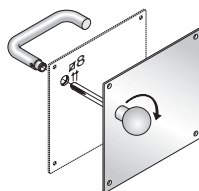
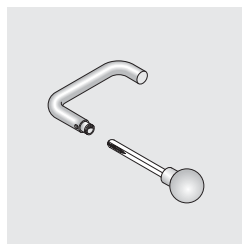
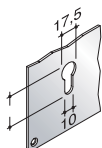
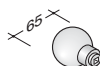
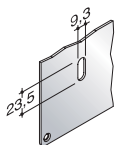

ART. 2500/2001/G

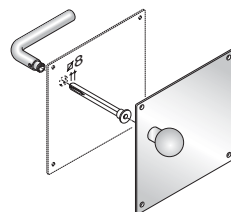

ART. 2500/2001/F

Disponibili anche con:
Available also with:
Disponible même avec:
Verfügbar auch mit:
Disponibles también:
Ook beschikbaar met:

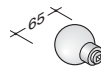
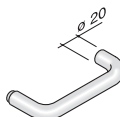
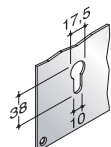
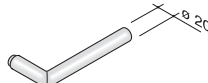
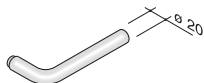
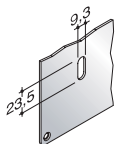

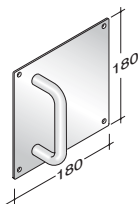
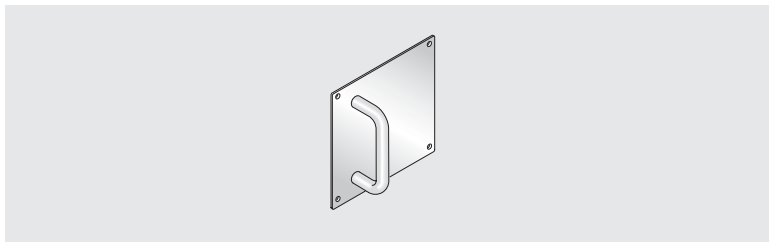

ART. 2201



ART. 2202



ART. 2203



ART. 2204

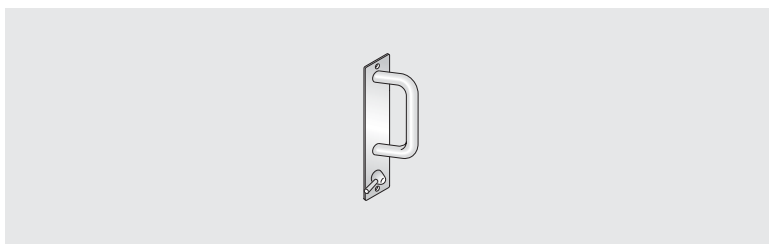

ART. 2211

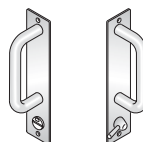

ART. 2215

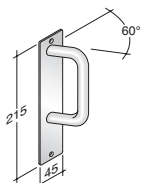

ART. 2221

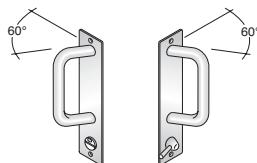

ART. 2225

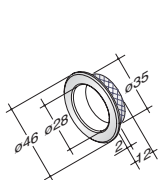
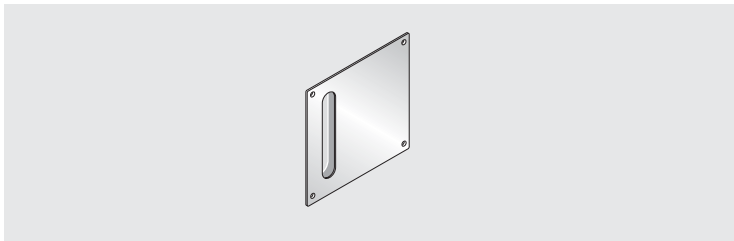

ART. 2305

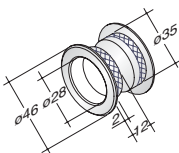

ART. 2305/D

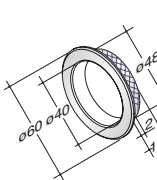

ART. 2306

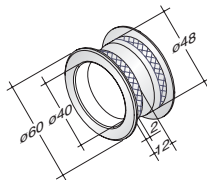

ART. 2306/D

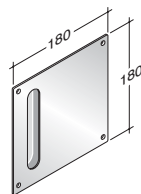

ART. 2301

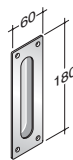

ART. 2302

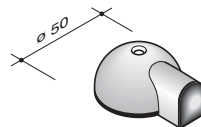
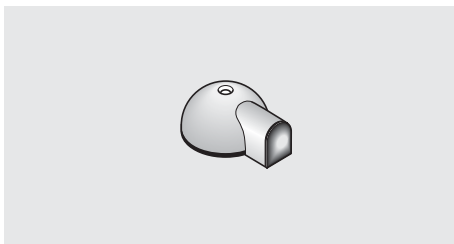

ART. 2040

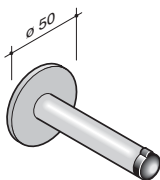
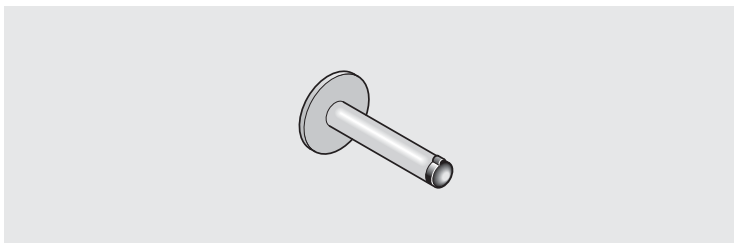

ART. 562-SS

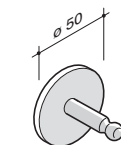

ART. 488-SS

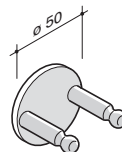

ART. 488-SS/D

10c

10c

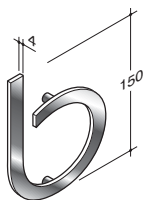

ART. 2600



ART. 2601



ART. 2602



ART. 2603



ART. 2604



ART. 2605



ART. 2606



ART. 2607



ART. 2608



ART. 2609

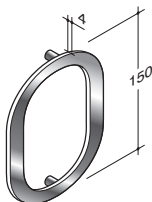

ART. 2600/A



ART. 2600/B



ART. 2600/C



ART. 2600/D

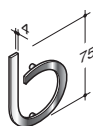

ART. 2600/P



ART. 2601/P



ART. 2602/P



ART. 2603/P



ART. 2604/P



ART. 2605/P



ART. 2606/P



ART. 2607/P



ART. 2608/P



ART. 2609/P

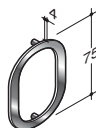

ART. 2600/A/P



ART. 2600/B/P



ART. 2600/C/P



ART. 2600/D/P

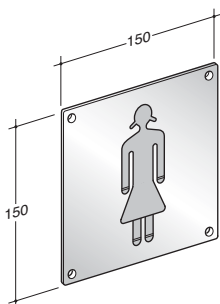
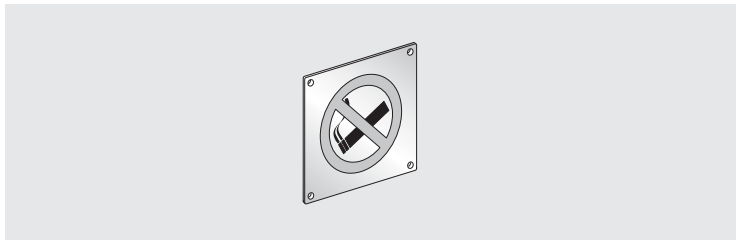

ART. 2401

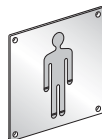

ART. 2402



ART. 2403



ART. 2404

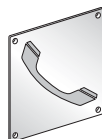

ART. 2405



ART. 2406



ART. 2401/D



ART. 2402/D



ART. 2403/D



ART. 2404/D

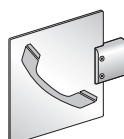

ART. 2405/D



ART. 2406/D

FISSAGGI
FIXINGS
FIXATIONS

BEFESTIGUNGEN
FIJACIONES
BEVESTIGING

ART. VM 001

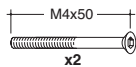

ART. VM 003



ART. VM 005

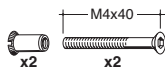

ART. VM 007

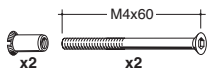

ART. VM 029

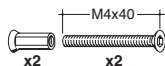

ART. VM 031

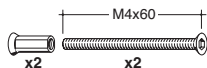

ART. VM 041



ART. VM 002

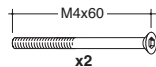

ART. VM 004

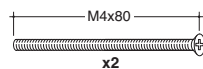

ART. VM 006

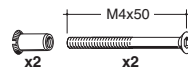

ART. VM 008

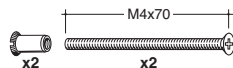

ART. VM 030

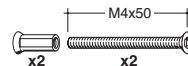

ART. VM 032

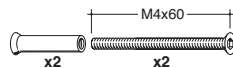

PROGRAMMA 200

PHOTO: Gabriele Basilico

ITALIANO
PROGRAMMA 200

Maniglioni tubolari di vario diametro in acciaio inox AISI 316L. Rigorosamente made in Italy. Il Programma 200 usa fissaggi che permettono il montaggio singolarmente o in coppia di tutti i modelli su qualunque tipologia di materiale (Legno, Metallo, PVC e Vetro). Finitura standard: satinata.

Finitura a richiesta: lucida.

Maniglioni speciali a richiesta (art.xxx/A).

ENGLISH
PROGRAMMA 200

Tubular pull handles available in a variety of diameters, manufactured in stainless steel AISI 316L.

Precision manufactured in Italy. The Programma 200 fixings permit simple or back to back installation on all models and have been designed to fit any type of material (wood, PVC, metal, glass).

Standard finishing: satin.

Finishing by request: bright.

Special pull handles on request (art.xxx/A).

FRANCAIS
PROGRAMMA 200

Poignées de tirage tubulaires de différents diamètres en acier inoxydable AISI 316L.

Exclusivement made in Italy. Les fixations du Programma 200 peuvent être montées seules ou par paire sur tous les modèles et sur tout type de portes (bois, PVC, métal et verre).

Finition standard: satinée.

Finition sur demande: polie.

Poignées de tirage spéciales sur demande (art.xxx/A).

DEUTSCH
PROGRAMMA 200

Stoßgriffe mit verschiedenen Durchmesser aus Edelstahl rostfrei 1.4404 Made in Italy.

Das Programma 200 ermöglicht entweder eine Einzel- sowie eine Paarweisebefestigung auf Türen und Sonderkonstruktionen aller Art (Holz, Kunststoff, Metall, Glas, Türrahmen aus Aluminium, usw). Standardausführung: Matt satiniert.

Hochglanz polierte Ausführung auf Anfrage lieferbar.

Stoßgriffen mit einem Sondermass auf Anfrage lieferbar (art.xxx/A).

ESPAÑOL
PROGRAMMA 200

Manillones tubulares de distintos diámetros en acero inoxidable AISI 316L.

Rigurosamente hecho en Italia. Las fijaciones del Programma 200 pueden montarse individualmente o a juego de tutti i modelli en puertas de cualquier tipología (madera, metal, PVC y cristal).

Acabados en serie: satinado.

Acabados bajo petición: brillante.

Manillones especiales bajo pedido (art.xxx/A).

NEDERLANDS
PROGRAMMA 200

Ronde buisvormige deurgrepen in verschillende diameters in roestvast staal AISI 316L.

Uitsluitend gefabriceerd in Italië.

Het Programma 200 gebruikt bevestigingen die het mogelijk maken om iedere greep zowel enkel als per paar te bevestigen op elk materiaal (Hout, Metaal, PVC of glas).

Standaardafwerking: mat geborsteld.

Afwerking op aanvraag: blinkend gepolijst.

Deurgrepen op maat op aanvraag (art. xxx/A).

PROGRAMMA 200
ITALIANO

Specifiche d'ordine	Codici	Confezioni standard
---------------------	--------	---------------------

Per tutti gli articoli:
 Codice articolo S= Satinato Maniglioni 2 Pezzi
 Tipologia di finitura P= Lucido

Fissaggi Pagina 76-77

ENGLISH

Order specifics	Codes	Standard Packing
-----------------	-------	------------------

For all articles:
 Article code S= Satin finish Pull handles 2 Pieces
 Fitting code P= Bright finish
 Type of finish

Fixings Page 76-77

FRANCAIS

Caractéristiques de la commande	Codes	Emballage standard
---------------------------------	-------	--------------------

Pour tous les articles:
 Code article S= Satiné Poignées 2 Pièces
 Typologie de finition P= Poli
 Code fixation

Fixation Page 76-77

DEUTSCH

Bestellangabe	Zusatzcode	Packeinheit zstück
---------------	------------	--------------------

Für alle Artikel:
 Artikelnummer S= Fein matt Stossgriffe 2 Stück
 Ausführung P= Hochglanz
 Befestigungsart poliert

Befestigungen Seite 76-77

ESPAÑOL

Características del pedido	Código	Confección estándar
----------------------------	--------	---------------------

Para todos los artículos:
 Código artículo S= Satinado Manillones 2 Piezas
 Tipo de acabado P= Brillante
 Código fijación

Fijaciones Pagina 76-77

NEDERLANDS

Besteidetails	Code	Standaardverpakking
---------------	------	---------------------

Voor alle artikelen:
 Artikelcode S= mat Deurgrepen 2 Stuks
 Afwerkingstype geborsteld
 Bevestigingstype P= blinkend
 geborsteld

Bevestiging Pagina 76-77

SISTEMA DI FISSAGGIO ANTIEFFRAZIONE PER FISSAGGI "SERIE/D" (BREVETTATO)

ANTI BREAK-IN FIXING SYSTEM FOR FIXING "SERIE/D" (PATENTED)

SYSTÈME DE FIXATION ANTI EFFRACTION POUR FIXATION "SERIE/D" (BREVETE)

BEFESTIGUNGSSET DIEBSTAHLSICHER FÜR BEFESTIGUNGEN "SERIE/D" (PATENTIERT)

SISTEMA DE FIJACIÓN ANTISABOTAJE PARA FIJACIONES "SERIE/D" (BREVETADO)

ANTIVANDALISMEBEVESTIGING VOOR BEVESTIGING "SERIE/D" (GEBREVETTEERD)

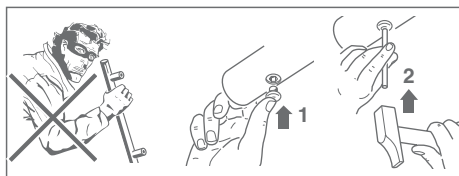

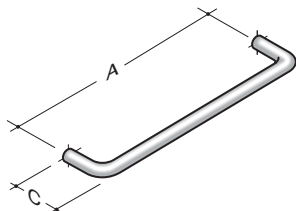

ART.	A	C	Ø
200.001	125	60	16
200.002	200	60	16
200.003	250	60	16
200.004	300	60	16
200.005	350	60	16
200.006	650	60	16
200.006/A			
270	200	65	20
271	250	65	20
272	300	65	20
273	350	65	20
273/A			
205	200	70	25
229	250	70	25
230	300	70	25
231	350	70	25
231/A			
212	230	85	30
206	300	85	30
213	320	85	30
244	350	85	30
245	650	85	30
245/A			
219	350	85	35
256	650	85	35
256/A			

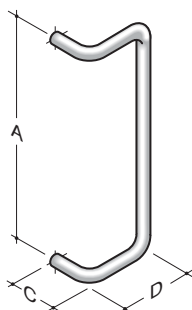

ART.	A	C	D	Ø
274	200	65	110	20
275	250	65	110	20
276	300	65	110	20
277	350	65	110	20
277/A				
207	200	70	120	25
232	250	70	120	25
233	300	70	120	25
234	350	70	120	25
234/A				
214	230	85	145	30
259	300	85	145	30
215	320	85	145	30
246	350	85	145	30
247	650	85	145	30
247/A				
220	350	85	155	35
257	650	85	155	35
257/A				

PROGRAMMA 200

ART.	A	C	Ø
200.101	180	65	20
200.102	230	65	20

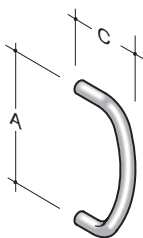

ART.	A	C	D	Ø
263	300	65	70	20
261	250	65	60	25
262	500	65	90	25
201	300	70	70	30
202	600	70	110	30
203	350	75	80	35
204	700	75	125	35



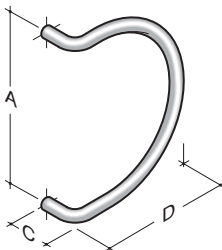

ART.	A	C	D	Ø
278	250	65	195	20
279	300	65	215	20
208	150	70	150	25
235	250	70	225	25
236	300	70	230	25
216	230	85	240	30
248	250	85	240	30
223	300	85	260	30
224	350	85	265	30
221	350	85	300	35

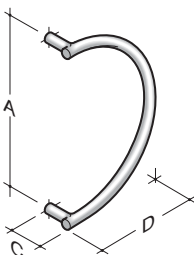

ART.	A	C	D	Ø
280	250	65	160	20
281	300	65	180	20
237	250	70	160	25
238	300	70	180	25
249	250	75	160	30
250	300	75	180	30
258	350	80	210	35

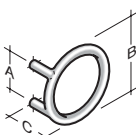

ART. 209

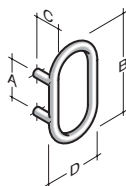

ART. 210

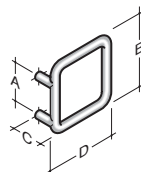

ART. 211

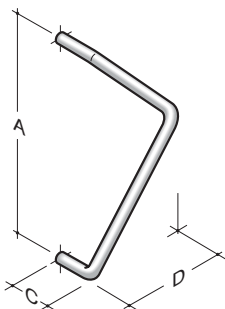

ART.	A	C	D	Ø
282	300	65	160	20
283	350	65	180	20
239	300	70	160	25
240	350	70	185	25
289	300	85	165	30
251	350	85	185	30
222	425	85	225	35

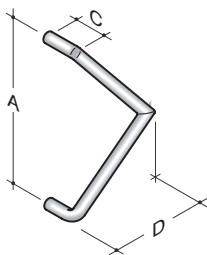
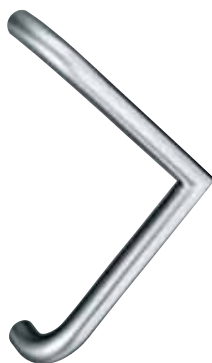

ART.	A	C	D	Ø
200.140	300	70	180	25
200.141	350	85	210	30
200.142	425	85	250	35

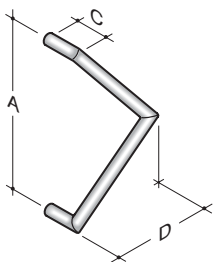

ART.	A	C	D	Ø
200.130	300	70	180	25
200.131	350	80	210	30
200.132	425	85	250	35

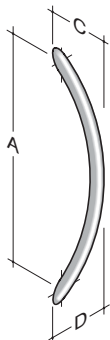

ART.	A	C	D	Ø
200.031	250	45	70	20
200.032	300	55	70	20
200.041	300	65	90	25
200.042	400	65	90	25
200.051	500	70	90	30
200.052	700	70	90	30

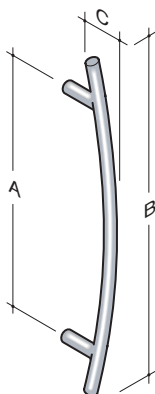
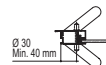
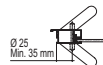
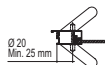

ART.	A	B	C	Ø
200.150	350	500	60	25
200.151	450	600	70	25
200.152	450	600	80	30
200.153	550	700	90	30

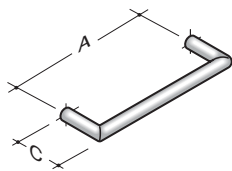

ART.	A	C	Ø
260	200	60	20
260/A			
265	300	65	25
265/A			
267	350	70	30
267/A			
268	350	75	35
268/A			

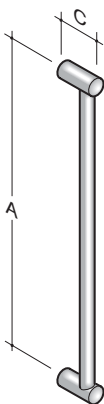

ART.	A	C	Ø
200.110	500	65	25
200.110/A			
200.120	650	70	30
200.120/A			

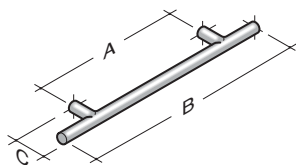

ART.	A	B	C	Ø
200.010	200	350	58	16
200.011	250	400	58	16
200.011/A				
285	250	400	65	20
286	300	450	65	20
286/A				
242	250	400	70	25
243	300	450	70	25
243/A				
252	300	450	75	30
253	350	500	75	30
253/A				
225	350	520	80	35
226	550	720	80	35
226/A				
296	1000	1200	85	40
296/A				

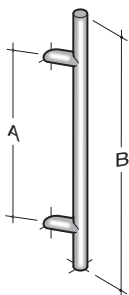

ART.	A	B	Ø
242/I	250	400	25
243/I	300	450	25
243/I/A			
252/I	300	450	30
253/I	350	500	30
253/I/A			

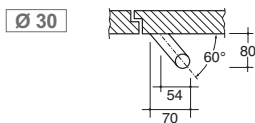
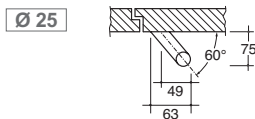

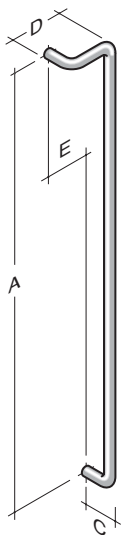

ART.	A	C	D	E	Ø
284	950	65	110	90	20
284/A					
241	950	70	120	95	25
241/A					
254	950	85	145	115	30
255	1200	85	145	115	30
255/A					
217	950	85	155	120	35
218	1200	85	155	120	35
218/A					

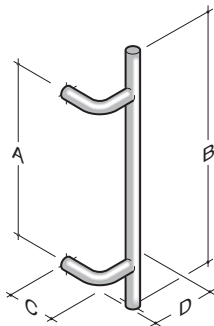

ART.	A	B	C	D	Ø
291	250	400	65	80	20
292	300	450	70	85	25
293	300	450	85	95	30
294	350	500	85	105	35

FISSAGGI SERIE /D
FIXINGS SERIES /D
FIXATIONS SERIE /D

BEFESTIGUNGEN SERIE /D
FIJACIONES SERIE /D
BEVESTIGING SERIE /D

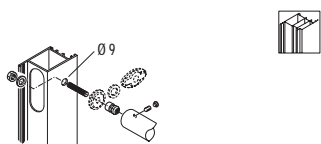

ART. 610/D-INOX

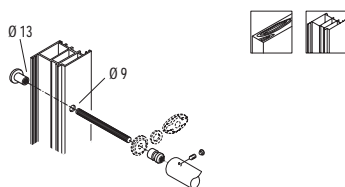

ART. 1110/D-INOX

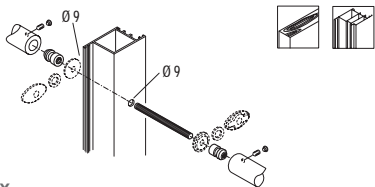

ART. 710/D-INOX

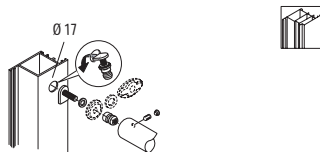

ART. 1210/D-INOX

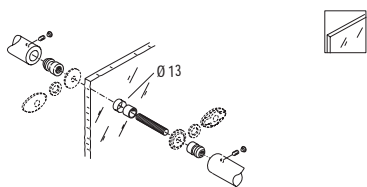

ART. 810/D-INOX

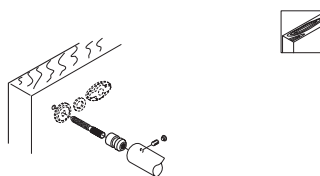

ART. 1310/D-INOX

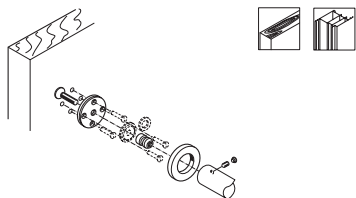

ART. 911/D - 912/D - 913/D - 914/D-INOX

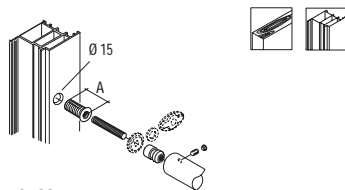

ART. 1410/D-INOX A=33 mm
ART. 1410/DL-INOX A=50 mm

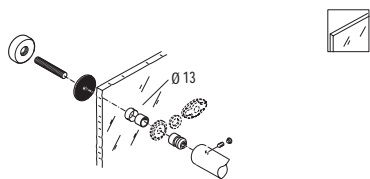

ART. 1011/D - 1012/D - 1013/D - 1014/D-1016/D-INOX

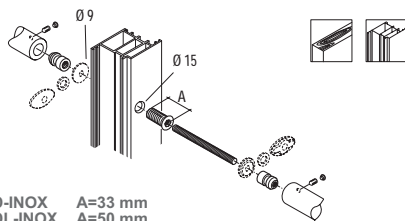

ART. 1510/D-INOX A=33 mm
ART. 1510/DL-INOX A=50 mm

LEGENDA - KEY TO SYMBOL - LÉGENDE - ZEICHENERKLÄRUNG - LEYENDA - LEGENDE

 Legno
Wood
Holz
Bois
Madera
Hout

 Alluminio / Pvc
Aluminium / Pvc
Aluminium / Pvc
Aluminium / Pvc
Aluminium / Pvc

 Vetro
Glass
Verre
Glass
Cristal
Glas

Spessori per protezione vetro in dotazione
Glass protections included
Protections pour verre incluses
Schutzteilen für Glas im Lieferumfang enthalten
Juntas de protección para cristal incluidas
Glasbeschermingsrubbers meegeleverd in de verpakking

PROGRAMMA 200

FISSAGGI SERIE // Ø 16 - 200.031 - 200.032 - 200.041 - 200.042

FIXINGS SERIES // Ø 16 - 200.031 - 200.032 - 200.041 - 200.042

FIXATIONS SERIE // Ø 16 - 200.031 - 200.032 - 200.041 - 200.042

BEFESTIGUNGEN SERIE // Ø 16 - 200.031 - 200.032 - 200.041 - 200.042

FIJACIONES SERIE // Ø 16 - 200.031 - 200.032 - 200.041 - 200.042

BEVESTIGING SERIE // Ø 16 - 200.031 - 200.032 - 200.041 - 200.042

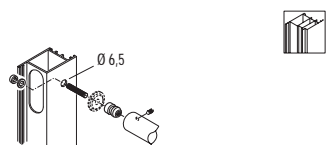
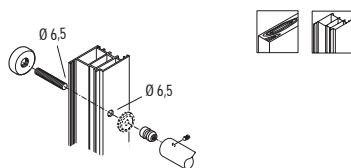
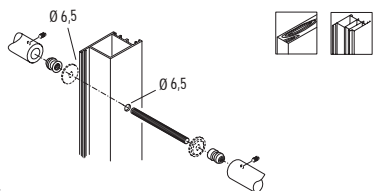
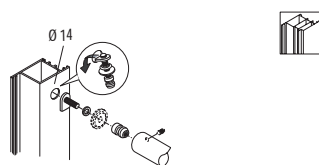
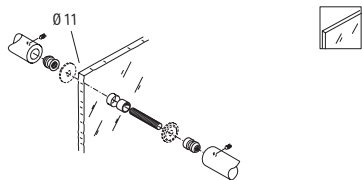
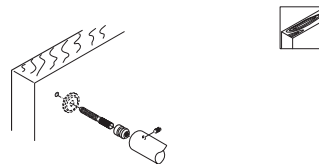
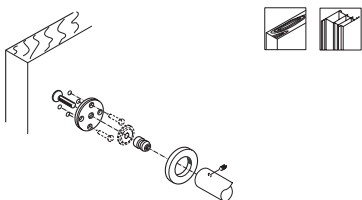
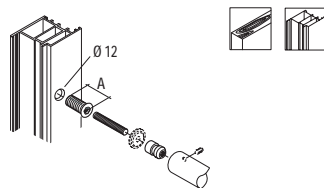
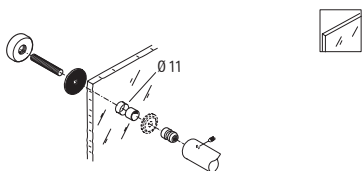
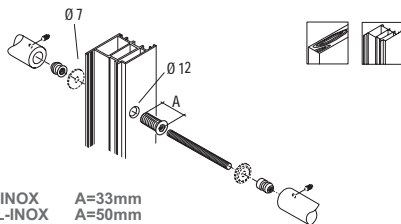
ART. 620/I-INOX

ART. 1120/I-INOX

ART. 720/I-INOX

ART. 1220/I-INOX

ART. 820/I-INOX

ART. 1320/I-INOX

ART. 925/I-INOX

ART. 1420/I-INOX A=33mm
ART. 1420/IL-INOX A=50mm

ART. 1025/I-INOX

ART. 1520/I-INOX A=33mm
ART. 1520/IL-INOX A=50mm
LEGENDA - KEY TO SYMBOL - LÉGENDE - ZEICHENERKLÄRUNG - LEYENDA - LEGENDE

Legno
 Wood
 Holz
 Bois
 Madera
 Hout

Alluminio / Pvc
 Aluminium / Pvc
 Aluminium / Pvc
 Aluminium / Pvc
 Aluminium / Pvc

Vetro
 Glass
 Verre
 Glass
 Cristal
 Glas

Spessori per protezione vetro in dotazione
 Glass protections included
 Protections pour verre incluses
 Schutzteilen für Glas im Lieferumfang enthalten
 Juntas de protección para cristal incluidas
 Glasbeschermingsrubbers meegeleverd in de verpakking



PHOTO: Gabriele Basilico

ITALIANO

PROGRAMMA 200E
Maniglioni tubolari ellittici in acciaio inox AISI 316L. Rigorosamente made in Italy.

Il Programma 200E usa fissaggi che permettono il montaggio singolarmente o in coppia di tutti i modelli su qualunque tipologia di materiale (Legno, Metallo, PVC e Vetro).

Finitura standard: satinata.

Finitura a richiesta: lucida.

Maniglioni speciali a richiesta (art.xxx/A).

ENGLISH

PROGRAMMA 200E
Tubular elliptical pull handles in stainless steel AISI 316L Precision manufactured in Italy.

The Programma 200E fixings permit simple or back to back installation on all models and have been designed to fit any type of material (wood, PVC, metal, glass).

Standard finishing: satin.

Finishing by request: bright.

Special pull handles on request (art.xxx/A).

FRANCAIS

PROGRAMMA 200E
Poignées de tirage tubulaires elliptiques en acier inoxydable AISI 316L. Exclusivement made in Italy.

Les fixations du Programma 200E peuvent être montées seules ou par paire sur tous les modèles et sur tout types de portes (bois, PVC, métal et verre).

Finition standard: satinée.

Finition sur demande: polie.

Poignées de tirage spéciales sur demande (art.xxx/A).

DEUTSCH

PROGRAMMA 200E

Oval Stoßgriffen aus Edelstahl rostfrei 1.4404. Made in Italy. Das Programma 200E ermöglicht entweder eine Einzel- sowie eine Paarweisebefestigung auf Türen und Sonderkonstruktionen aller Art (Holz, Kunststoff, Metall, Glas, Türrahmen aus Aluminium, usw). Standardausführung: Matt satiniert.

Hochglanz polierte Ausführung auf Anfrage lieferbar.

Stoßgriffen mit einem Sondermass auf Anfrage lieferbar (art.xxx/A).

ESPAÑOL

PROGRAMMA 200E

Manillones tubulares elípticos en acero inoxidable AISI 316L. Rigurosamente hecho en Italia.

Las fijaciones del Programa 200E pueden montarse individualmente o a juego de tutti i modelli en puertas de cualquier tipología (madera, metal, PVC y cristal).

Acabados en serie: satinado.

Acabados bajo petición : brillante.

Manillones especiales bajo pedido (art.xxx/A).

NEDERLANDS

PROGRAMMA 200E

Ellipsvormige buisvormige deurgrepen in roestvast staal AISI 316L. Uitsluitend gefabriceerd in Italië

Het Programma 200E gebruikt bevestigingen die het mogelijk maken om iedere greep zowel enkel als per paar te bevestigen op elk materiaal (Hout, Metaal, PVC of glas).

Standaardafwerking: mat geborsteld.

Afwerking op aanvraag: blinkend gepolijst.

Deurgrepen op maat op aanvraag (art. xxx/A).

PROGRAMMA 200E
ITALIANO

Specifiche d'ordine	Codici	Confezioni standard	
---------------------	--------	---------------------	--

Per tutti gli articoli:
 Codice articolo **S=** Satinato Maniglioni **2 Pezzi**
 Tipologia di finitura **P=** Lucido

Fissaggi **Pagina 83**

ENGLISH

Order specifics	Codes	Standard Packing	
-----------------	-------	------------------	--

For all articles:
 Article code **S=** Satin finish Pull handles **2 Pieces**
 Fitting code **P=** Bright finish
 Type of finish

Fixings **Page 83**

FRANCAIS

Caractéristiques de la commande	Codes	Emballage standard	
---------------------------------	-------	--------------------	--

Pour tous les articles:
 Code article **S=** Satiné Poignées **2 Pièces**
 Typologie de finition **P=** Poli
 Code fixation

Fixation **Page 83**

DEUTSCH

Bestellangabe	Zusatzcode	Packeinheit zstück	
---------------	------------	--------------------	--

Für alle Artikel:
 Artikelnummer **S=** Fein matt Satiniert **2 Stück**
 Ausführung **P=** Hochglanz poliert
 Befestigungsart

Befestigungen **Seite 83**

ESPAÑOL

Características del pedido	Código	Confección estándar	
----------------------------	--------	---------------------	--

Para todos los artículos:
 Código artículo **S=** Satinado Manillones **2 Piezas**
 Tipo de acabado **P=** Brillante
 Código fijación

Fijaciones **Página 83**

NEDERLANDS

Besteiddetails	Code	Standaardverpakking	
----------------	------	---------------------	--

Voor alle artikelen:
 Artikelcode **S=** mat geborsteld Deurgrepen **2 Stuks**
 Afwerkingstype **P=** blinkend geborsteld
 Bevestigingstype

Bevestiging **Pagina 83**

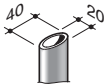

SISTEMA DI FISSAGGIO ANTIEFFRAZIONE PER FISSAGGI "SERIE/D" (BREVETTATO)
 ANTI BREAK-IN FIXING SYSTEM FOR FIXING "SERIE/D" (PATENTED)
 SYSTÈME DE FIXATION ANTI EFRACITION POUR FIXATION "SERIE/D" (BREVETE)
 BEFESTIGUNGSSET DIEBSTAHLSICHER FÜR BEFESTIGUNGEN "SERIE/D" (PATENTIERT)
 SISTEMA DE FIJACIÓN ANTISABOTAJE PARA FIJACIONES "SERIE/D" (BREVETADO)
 ANTIVANDALISMEBEVESTIGING VOOR BEVESTIGING "SERIE/D" (GEBREVETTEERD)

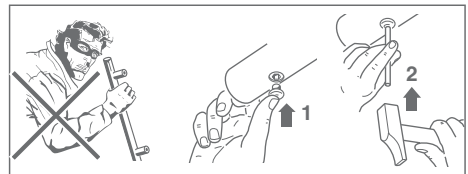

ART.	A	C	D
200E-021	350	60	200
200E-022	425	60	240

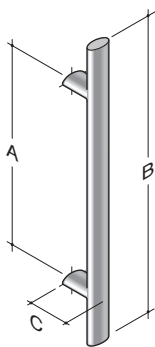
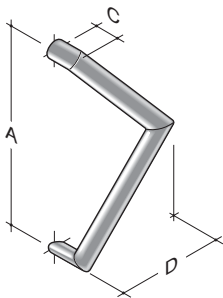
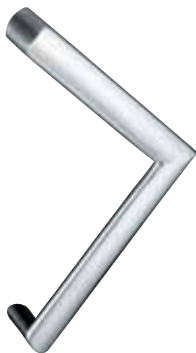

ART.	A	B	C
200E-011	350	520	65
200E-012	550	720	65
200E-012/A			

ART.	A	B	C
200E-001	350	370	60
200E-002	650	670	60

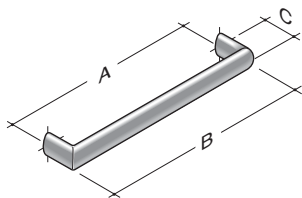

ART.	A	B	C
200E-031	350	370	60
200E-032	650	670	60

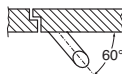
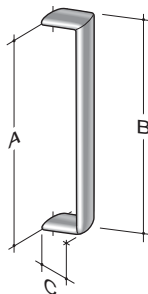

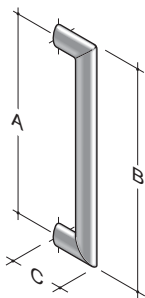

ART.	A	B	C
200E-041	350	390	80
200E-042	650	690	80

FISSAGGI SERIE /D
FIXINGS SERIES /D
FIXATIONS SERIE /D

BEFESTIGUNGEN SERIE /D
FIJACIONES SERIE /D
BEVESTIGING SERIE /D

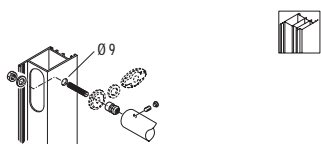

ART. 610/D-INOX

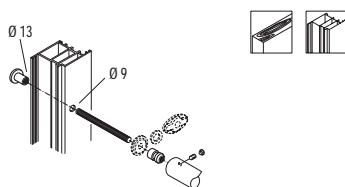

ART. 1110/D-INOX

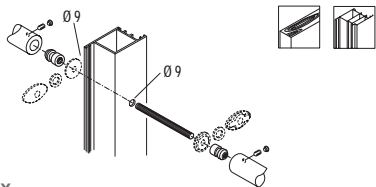

ART. 710/D-INOX

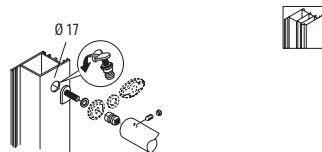

ART. 1210/D-INOX

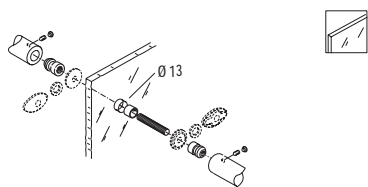

ART. 810/D-INOX

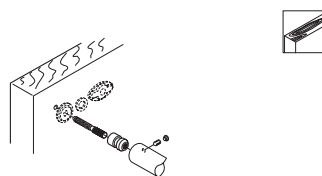

ART. 1310/D-INOX

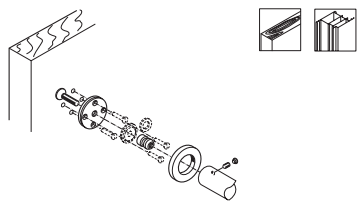

ART. 911/D - 912/D - 913/D - 914/D-INOX

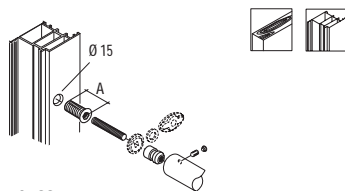

ART. 1410/D-INOX A=33 mm
ART. 1410/DL-INOX A=50 mm

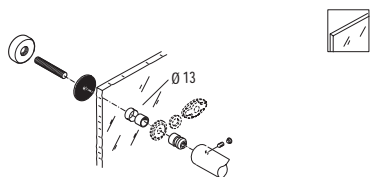

ART. 1011/D - 1012/D - 1013/D - 1014/D-1016/D-INOX

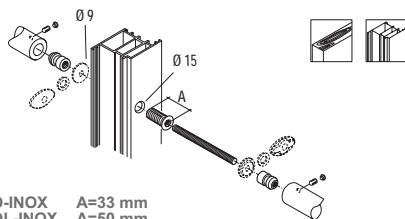

ART. 1510/D-INOX A=33 mm
ART. 1510/DL-INOX A=50 mm

LEGENDA - KEY TO SYMBOL - LÉGENDE - ZEICHENERKLÄRUNG - LEYENDA - LEGENDE

 Legno
Wood
Holz
Bois
Madera
Hout

 Alluminio / Pvc
Aluminium / Pvc
Aluminium / Pvc
Aluminium / Pvc
Aluminium / Pvc

 Vetro
Glass
Verre
Glass
Cristal
Glas

Spessori per protezione vetro in dotazione
Glass protections included
Protections pour verre incluses
Schutzteilen für Glas im Lieferumfang enthalten
Juntas de protección para cristal incluidas
Glasbeschermingsrubbers meegeleverd in de verpakking

PROGRAMMA 200Q

ITALIANO
PROGRAMMA 200Q

Maniglioni tubolari con profilo quadrato in acciaio inox AISI 316L.
Rigorosamente made in Italy.

Il Programma 200Q usa fissaggi che permettono il montaggio singolarmente o in coppia di tutti i modelli su qualunque tipologia di materiale (Legno, Metallo, PVC e Vetro).

Finitura standard: satinata.

Finitura a richiesta: lucida.

Maniglioni speciali a richiesta (art.xxx/A).

DEUTSCH
PROGRAMMA 200Q

Stoßgriff in Edelstahl Werkstoff 1.4404 mit quadratischem Profil.
Made in Italy.

Das Programma 200E ermöglicht entweder eine Einzel- sowie eine Paarweisebefestigung auf Türen und Sonderkonstruktionen aller Art (Holz, Kunststoff, Metall, Glas, Türrahmen aus Aluminium, usw).

Standardausführung: Matt satiniert.

Hochglanz polierte Ausführung auf Anfrage lieferbar.

Stoßgriffen mit einem Sondermass auf Anfrage lieferbar (art.xxx/A).

ENGLISH
PROGRAMMA 200Q

Tubular pull handles with square profile in stainless steel AISI 316L.
Precision manufactured in Italy.

The Programma 200E fixings permit simple or back to back installation on all models and have been designed to fit any type of material (wood, PVC, metal, glass).

Standard finishing: satin.

Finishing by request: bright.

Special pull handles on request (art.xxx/A).

ESPAÑOL
PROGRAMMA 200Q

Manillones tubulares de perfil cuadrado en acero inoxidable AISI 316L. Rigurosamente hecho en Italia.

Las fijaciones del Programa 200E pueden montarse individualmente o a juego de tutti i modelli en puertas de cualquier tipología (madera, metal, PVC y cristal).

Acabados en serie: satinado.

Acabados bajo petición : brillante.

Manillones especiales bajo pedido (art.xxx/A).

FRANCAIS
PROGRAMMA 200Q

Poignées de tirage tubulaires avec profil carré en acier inoxydable AISI 316L. Exclusivement made in Italy.

Les fixations du Programma 200E peuvent être montées seules ou par paire sur tous les modèles et sur tout types de portes (bois, PVC, métal et verre).

Finition standard: satinée.

Finition sur demande: polie.

Poignées de tirage spéciales sur demande (art.xxx/A).

NEDERLANDS
PROGRAMMA 200Q

Vierkante buisvormige deurgrepen in roestvast staal AISI 316L.

Uitsluitend gefabriceerd in Italië

Het Programma 200E gebruikt bevestigingen die het mogelijk maken om iedere greep zowel enkel als per paar te bevestigen op elk materiaal (Hout, Metaal, PVC of glas).

Standardafwerking: mat geborsteld.

Afwerking op aanvraag: blinkend gepolijst.

Deurgrepen op maat op aanvraag (art. xxx/A).

PROGRAMMA 200Q
ITALIANO

Specifiche d'ordine	Codici	Confezioni standard	
---------------------	--------	---------------------	--

Per tutti gli articoli:
Codice articolo
Tipologia di finitura
Tipo di fissaggio

S= Satinato
P= Lucido

Maniglioni 2 Pezzi

Fissaggi **Pagina 87**

ENGLISH

Order specifics	Codes	Standard Packing	
-----------------	-------	------------------	--

For all articles:
Article code
Fitting code
Type of finish

S= Satin finish
P= Bright finish

Pull handles 2 Pieces

Fixings **Page 87**

FRANCAIS

Caractéristiques de la commande	Codes	Emballage standard	
---------------------------------	-------	--------------------	--

Pour tous les articles:
Code article
Typologie de finition
Code fixation

S= Satiné
P= Poli

Poignées 2 Pièces

Fixation **Page 87**

DEUTSCH

Bestellangabe	Zusatzcode	Packeinheit zstück	
---------------	------------	--------------------	--

Für alle Artikel:
Artikelnummer
Ausführung
Befestigungsart

S= Fein matt Satiniert
P= Hochglanz poliert

Stossgriffe 2 Stück

Befestigungen **Seite 87**

ESPAÑOL

Características del pedido	Código	Confección estándar	
----------------------------	--------	---------------------	--

Para todos los artículos:
Código artículo
Tipo de acabado
Código fijación

S= Satinado
P= Brillante

Manillones 2 Piezas

Fijaciones **Página 87**

NEDERLANDS

Besteidetails	Code	Standaardverpakking	
---------------	------	---------------------	--

Voor alle artikelen:
Artikelcode
Afwerkingstype
Bevestigingstype

S= mat geborsteld
P= blinkend geborsteld

Deurgrepen 2 Stuks

Bevestiging **Pagina 87**

SISTEMA DI FISSAGGIO ANTIEFFRAZIONE PER FISSAGGI "SERIE/D" (BREVETTATO)

ANTI BREAK-IN FIXING SYSTEM FOR FIXING "SERIE/D" (PATENTED)

SYSTÈME DE FIXATION ANTI EFFRACTION POUR FIXATION "SERIE/D" (BREVETE)

BEFESTIGUNGSSET DIEBSTAHLSICHER FÜR BEFESTIGUNGEN "SERIE/D" (PATENTIERT)

SISTEMA DE FIJACIÓN ANTISABOTAJE PARA FIJACIONES "SERIE/D" (BREVETADO)

ANTIVANDALISMEBEVESTIGING VOOR BEVESTIGING "SERIE/D" (GEBREVETTEERD)

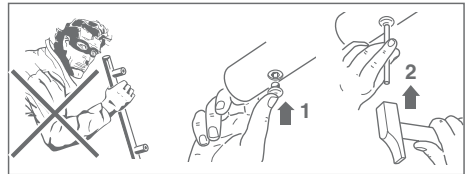

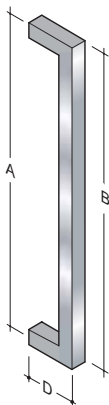

ART.	A	B	D	Ø
200Q-001	200	220	60	20
200Q-002	300	320	60	20
200Q-002/A				
200Q-011	300	325	65	25
200Q-012	650	675	65	25
200Q-012/A				
200Q-021	650	680	70	30
200Q-021/A				
200Q-031	650	685	75	35
200Q-031/A				

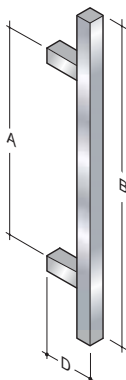

ART.	A	B	D	Ø
200Q-101	250	400	65	20
200Q-102	300	450	65	20
200Q-102/A				
200Q-111	300	450	70	25
200Q-112	350	500	70	25
200Q-112/A				
200Q-121	500	650	75	30
200Q-121/A				
200Q-131	600	770	80	35
200Q-131/A				
200Q-141	1000	1200	85	40
200Q-141/A				

FISSAGGI SERIE /D
FIXINGS SERIES /D
FIXATIONS SERIE /D

BEFESTIGUNGEN SERIE /D
FIJACIONES SERIE /D
BEVESTIGING SERIE /D

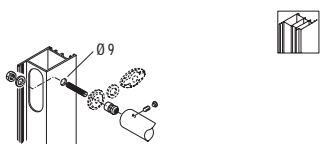

ART. 610/D-INOX

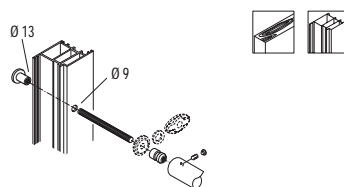

ART. 1110/D-INOX

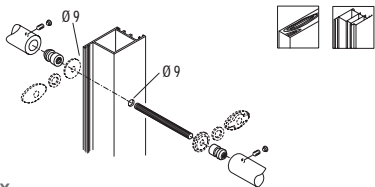

ART. 710/D-INOX

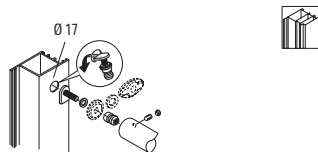

ART. 1210/D-INOX

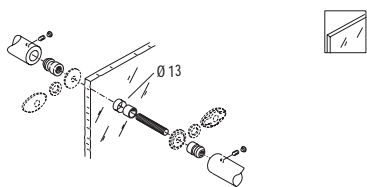

ART. 810/D-INOX

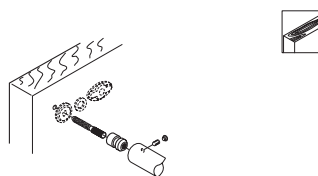

ART. 1310/D-INOX

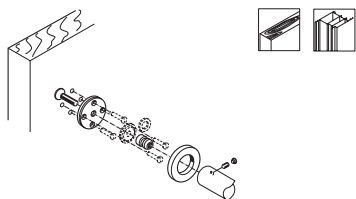

ART. 911/D - 912/D - 913/D - 914/D-INOX

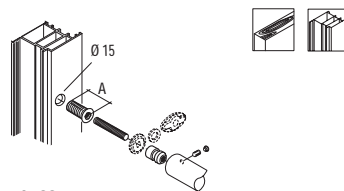

ART. 1410/D-INOX A=33 mm
ART. 1410/DL-INOX A=50 mm

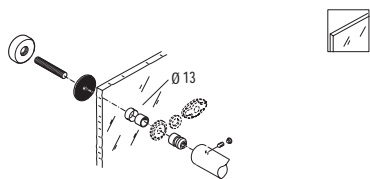

ART. 1011/D - 1012/D - 1013/D - 1014/D-1016/D-INOX

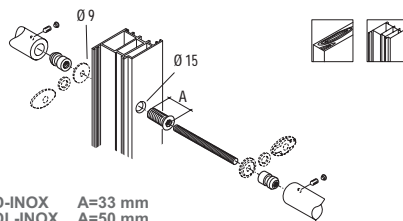

ART. 1510/D-INOX A=33 mm
ART. 1510/DL-INOX A=50 mm

LEGENDA - KEY TO SYMBOL - LÉGENDE - ZEICHENERKLÄRUNG - LEYENDA - LEGENDE

Legno
Wood
Holz
Bois
Madera
Hout

Alluminio / Pvc
Aluminium / Pvc
Aluminium / Pvc
Aluminium / Pvc
Aluminium / Pvc

Vetro
Glass
Verre
Glass
Cristal
Glas

Spessori per protezione vetro in dotazione
Glass protections included
Protections pour verre incluses
Schutzteilen für Glas im Lieferumfang enthalten
Juntas de protección para cristal incluidas
Glasbeschermingsrubbers meegeleverd in de verpakking

PROGRAMMA 200P



ITALIANO

PROGRAMMA 200P

Maniglioni con profilo piatto in acciaio inox AISI 316L.
Rigorosamente made in Italy.

Il Programma 200P usa fissaggi che permettono il montaggio singolarmente o in coppia di tutti i modelli su qualunque tipologia di materiale (Legno, Metallo, PVC e Vetro).

Finitura standard: satinata.

Finitura a richiesta: lucida.

Maniglioni speciali a richiesta (art.xxx/A).

DEUTSCH

PROGRAMMA 200P

Stoßgriff in Edelstahl Werkstoff 1.4404 mit Flachprofil. Made in Italy.
Das Programma 200P ermöglicht entweder eine Einzel- sowie eine
Paarweisebefestigung auf Türen und Sonderkonstruktionen aller Art
(Holz, Kunststoff, Metall, Glas, Türrahmen aus Aluminium, usw).
Standardausführung: Matt satiniert.

Hochglanz polierte Ausführung auf Anfrage lieferbar.

Stoßgriffen mit einem Sondermass auf Anfrage lieferbar (art.xxx/A).

ENGLISH

PROGRAMMA 200P

Flat profile pull handles in stainless steel AISI 316L.

Precision manufactured in Italy.

The Programma 200P fixings permit simple or back to back installation on all models and have been designed to fit any type of material (wood, PVC, metal, glass).

Standard finishing: satin.

Finishing by request: bright.

Special pull handles on request (art.xxx/A).

ESPAÑOL

PROGRAMMA 200P

Manillones de perfil plano en acero inoxidable AISI 316L.
Rigorosamente fabricado en Italia.

Las fijaciones del Programa 200P pueden montarse individualmente o a juego de tutti i modelli en puertas de cualquier tipología (madera, metal, PVC y cristal).

Acabados en serie: satinado.

Acabados bajo petición : brillante.

Manillones especiales bajo pedido (art.xxx/A).

FRANCAIS

PROGRAMMA 200P

Poignées de tirage avec profil plat en acier inoxydable AISI 316L.
Exclusivement made in Italy.

Les fixations du Programma 200P peuvent être montées seules ou par paire sur tous les modèles et sur tout types de portes (bois, PVC, métal et verre).

Finition standard: satinée.

Finition sur demande: polie.

Poignées de tirage spéciales sur demande (art.xxx/A).

NEDERLANDS

PROGRAMMA 200P

Plat profiel deurgreep in roestvast staal AISI 316L.

Uitsluitend gefabriceerd in Italië

Het Programma 200P gebruikt bevestigingen die het mogelijk maken om iedere greep zowel enkel als per paar te bevestigen op elk materiaal (Hout, Metaal, PVC of glas).

Standaardafwerking: mat geborsteld.

Afwerking op aanvraag: blinkend gepolijst.

Deurgrepen op maat op aanvraag (art. xxx/A).

PROGRAMMA 200P
ITALIANO

Specifiche d'ordine	Codici	Confezioni standard	
---------------------	--------	---------------------	--

Per tutti gli articoli:
Codice articolo
Tipologia di finitura
Tipo di fissaggio

S= Satinato
P= Lucido

Maniglioni **2 Pezzi**

Fissaggi **Pagina 93**

ENGLISH

Order specifics	Codes	Standard Packing	
-----------------	-------	------------------	--

For all articles:
Article code
Fitting code
Type of finish

S= Satin finish
P= Bright finish

Pull handles **2 Pieces**

Fixings **Page 93**

FRANCAIS

Caractéristiques de la commande	Codes	Emballage standard	
---------------------------------	-------	--------------------	--

Pour tous les articles:
Code article
Typologie de finition
Code fixation

S= Satiné
P= Poli

Poignées **2 Pièces**

Fixation **Page 93**

DEUTSCH

Bestellangabe	Zusatzcode	Packeinheit zstück	
---------------	------------	--------------------	--

Für alle Artikel:
Artikelnummer
Ausführung
Befestigungsart

S= Fein matt Satiniert
P= Hochglanz poliert

Stossgriffe **2 Stück**

Befestigungen **Seite 93**

ESPAÑOL

Características del pedido	Código	Confección estándar	
----------------------------	--------	---------------------	--

Para todos los artículos:
Código artículo
Tipo de acabado
Código fijación

S= Satinado
P= Brillante

Manillones **2 Piezas**

Fijaciones **Página 93**

NEDERLANDS

Besteidetails	Code	Standaardverpakking	
---------------	------	---------------------	--

Voor alle artikelen:
Artikelcode
Afwerkingstype
Bevestigingstype

S= mat geborsteld
P= blinkend geborsteld

Deurgrepen **2 Stuks**

Bevestiging **Pagina 93**

SISTEMA DI FISSAGGIO ANTIEFFRAZIONE PER FISSAGGI "SERIE/D" (BREVETTATO)

ANTI BREAK-IN FIXING SYSTEM FOR FIXING "SERIE/D" (PATENTED)

SYSTÈME DE FIXATION ANTI EFFRACTION POUR FIXATION "SERIE/D" (BREVETE)

BEFESTIGUNGSSET DIEBSTAHLSICHER FÜR BEFESTIGUNGEN "SERIE/D" (PATENTIERT)

SISTEMA DE FIJACIÓN ANTISABOTAJE PARA FIJACIONES "SERIE/D" (BREVETADO)

ANTIVANDALISMEBEVESTIGING VOOR BEVESTIGING "SERIE/D" (GEBREVETTEERD)

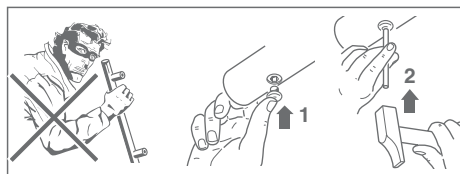

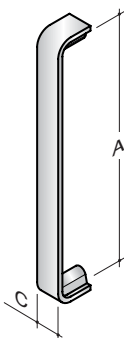

ART.	A	C
200P-001	300	30
200P-001/A		



ART.	A	C	D
200P-011	300	30	90

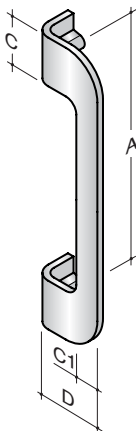

ART.	A	C	C1	D
200P-021	300	60	30	90

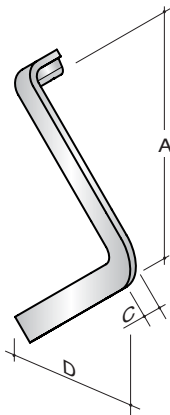

ART.	A	C	D
200P-031	300	30	175

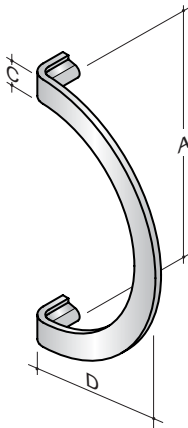

ART.	A	C	D
200P-041	300	30	180

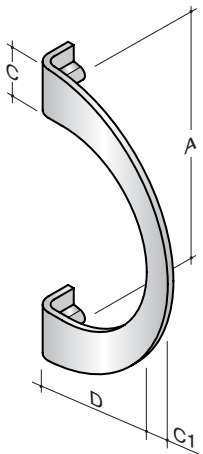

ART.	A	C	C1	D
200P-051	300	60	30	190

PROGRAMMA 200P

ART.	A	C	D	E
200P-061	1200	30	90	60

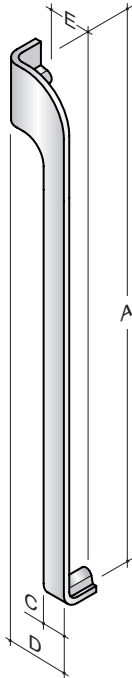

FISSAGGI SERIE //
FIXINGS SERIES //
FIXATIONS SERIE //

BEFESTIGUNGEN SERIE //
FIJACIONES SERIE //
BEVESTIGING SERIE //

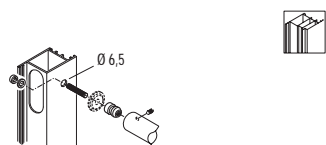

ART. 620/I-INOX

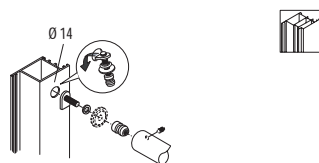

ART. 1220/I-INOX

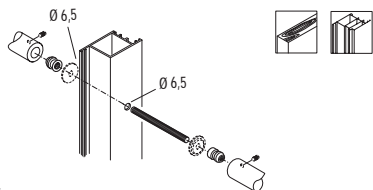

ART. 720/I-INOX

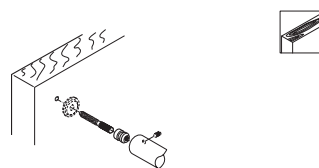

ART. 1320/I-INOX

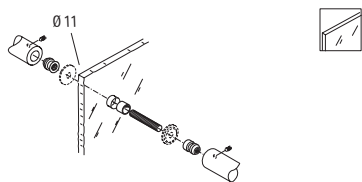

ART. 820/I-INOX

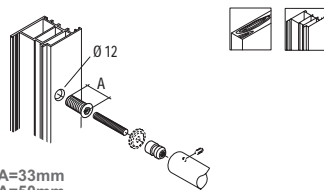

ART. 1420/I-INOX A=33mm
ART. 1420/IL-INOX A=50mm

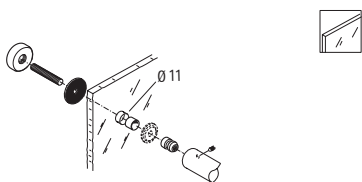

ART. 1025/I-INOX

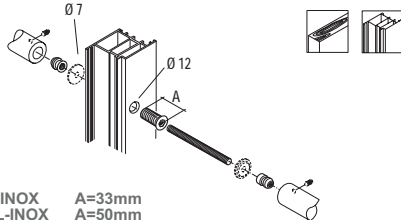

ART. 1520/I-INOX A=33mm
ART. 1520/IL-INOX A=50mm

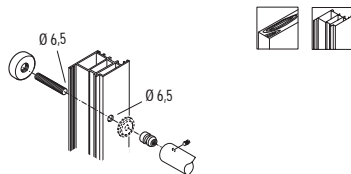

ART. 1120/I-INOX

LEGENDA - KEY TO SYMBOL - LÉGENDE - ZEICHENERKLÄRUNG - LEYENDA - LEGENDE

 Legno
Wood
Holz
Bois
Madera
Hout

 Alluminio / Pvc
Aluminium / Pvc
Aluminium / Pvc
Aluminium / Pvc
Aluminium / Pvc

 Vetro
Glass
Verre
Glass
Cristal
Glas

Spessori per protezione vetro in dotazione
Glass protections included
Protections pour verre incluses
Schutzteilen für Glas im Lieferumfang enthalten
Juntas de protección para cristal incluidas
Glasbeschermingsrubbers meegeleverd in de verpakking

PROGRAMMA K-LOCK

PHOTO: Gabriele Basilio

ITALIANO
PROGRAMMA K-LOCK

Maniglioni tubolari con serratura in acciaio inox AISI 316L.

Rigorosamente made in Italy. Il Programma K-LOCK permette il fissaggio singolo o in coppia di tutti i modelli su qualunque tipologia di serramento (Legno, Metallo, PVC e Vetro).

Finitura standard: satinata.

Finitura a richiesta: lucida.

Maniglioni speciali a richiesta (art.xxx/A).

Sistema di chiusura brevettato PBA.

DEUTSCH
PROGRAMMA K-LOCK

Strossgriffe mit Schlob mit verschiedenen Durchmessern aus Edelstahl rostfrei 1.4404 Made in Italy. Die Befestigungen der Programma K-LOCK ermöglichen eine Einzelbefestigung und eine Beidseitige Befestigung von allen Modellen auf alle Türarten (Holz, Kunststoff, Metal, Glas, Türrahmen aus Aluminium, usw).

Standardausführung: Matt satiniert.

Hochglanz polierte Ausführung auf Anfrage lieferbar.

Stossgriffen mit einem Sondermass auf Anfrage lieferbar (art.xxx/A).

PBA patentiertes Verschlussystem.

ENGLISH
PROGRAMMA K-LOCK

Tubular pull handles with lock available in a variety of diameters, manufactured in stainless steel AISI 316L. Precision manufactured in Italy. The Programma K-LOCK fixings permit simple or back to back installation on all models and have been designed to fit any type of material (Wood, PVC, Metal, Glass).

Standard finishing: satin.

Finishing by request: bright.

Special pull handles on request (art.xxx/A).

PBA patented closing system.

ESPAÑOL
PROGRAMMA K-LOCK

Manillones tubulares con cerradura de distintos diámetros en acero inoxidable AISI 316L. Rigurosamente hecho en Italia. Las fijaciones del Programa K-LOCK pueden montarse individualmente o a juego, todos los modelos en puertas de cualquier tipología (Madera, Metal, PVC y Cristal).

Acabados en serie: satinado.

Acabados bajo petición: brillante.

Manillones especiales bajo pedido (art.xxx/A).

Sistema de cierre patentado PBA

FRANCAIS
PROGRAMMA K-LOCK

Poignées de tirage tubulaires avec serrure de différents diamètres en acier inoxydable AISI 316L. Exclusivement made in Italy. Les fixations du Programm K-LOCK peuvent être montées seules ou par paire sur toutes les versions et sur tout types de portes (Bois, PVC, Métal et Vitre).

Finition standard: satinée.

Finition sur demande: polie.

Poignées de tirage spéciales sur demande (art.xxx/A)

Système de fermeture breveté PBA.

NEDERLANDS
PROGRAMMA K-LOCK

Ronde buisvormige deurgrepen met slot in verschillende diameters in roestvast staal AISI 316L. Uitsluitend gefabriceerd in Italië. Het K-LOCK Programma omvat bevestigingen die de montage mogelijk maken van zowel enkele als dubbele grepen van alle modellen voor elk type deur (Hout, Metaal, PVC of Glas).

Standardafwerking: mat geborsteld.

Afwerking op aanvraag: blinkend gepolijst.

Deurgrepen op maat op aanvraag (art. xxx/A).

Gebrevetteerd sluitsysteem PBA

PROGRAMMA K-LOCK
ITALIANO

Specifiche d'ordine	Codici	Confezioni standard	
Per tutti gli articoli: Codice articolo Tipologia di finitura Tipo di fissaggio (200C-V)	S= Satinato P= Lucido PVD (200C-V) verniciati RAL (200C-V)	Maniglioni	1 Pezzo 1 Coppia

Fissaggi serie 200C-V Pagina 104
Fissaggi altre serie:
standard in dotazione spessore 8-18 mm

ENGLISH

Order specifics	Codes	Standard Packing	
For all articles: Article code Type of finish Fitting code (200C-V)	S= Satin finish P= Bright finish PVD (200C-V) varnished RAL (200C-V)	Pull handles	1 Piece 1 Pair

Fixings serie 200C-V Page 104
Fittings of other series:
standard supplied as outfit, thickness 8-18 mm

FRANCAIS

Caractéristiques de la commande	Codes	Emballage standard	
Pour tous les articles: Code article Typologie de finition Code Fixation (200C-V)	S= Satiné P= Poli PVD (200C-V) verni RAL (200C-V)	Poignées	1 Pièce 1 Paire

Fixations serie 200C-V Page 104
Fixations des autres séries:
fournie standard, épaisseur 8-18 mm

DEUTSCH

Bestellangabe	Zusatzcode	Packeinheit zstück	
Für alle Artikel: Artikelnummer Ausführung Befestigungsart (200C-V)	S= Fein matt Satiert P= Hochglanz poliert PVD (200C-V) Lackiert RAL (200C-V)	Stoßgriffe	1 Stück 1 Paar

Befestigungen serie (200C-V) Seite 104
Befestigungssätze für die andere Serie:
Standard im Lieferumfang enthalten,
Türstärke zwischen 8 bis 18 mm

ESPAÑOL

Características del pedido	Código	Confección estándar	
Para todos los artículos: Código artículo Tipo de acabado Código fijación (200C-V)	S= Satinado P= Brillante PVD (200C-V) barnizado RAL (200C-V)	Manillones	1 Pieza 1 Juego

Fijaciones serie 200C-V Pagina 104
Fijaciones de otras series:
estándar provisto, grueso 8-18 mm

NEDERLANDS

Besteidetails	Code	Standaardverpakking	
Voor alle artikelen: Artikelcode Afwerkingstype Bevestigingstype (200C-V)	S= mat geborsteld P= blinkend geborsteld PVD (200C-V) gelakt in RAL kleur (200C-V)	Deurgrepen	1 Stuks 1 Paar

Bevestiging serie 200C-V Pagina 104
Bevestigingen voor andere series:
deurdikte 8-18 mm standaard meegeleverd

SISTEMA DI FISSAGGIO ANTIEFFRAZIONE PER FISSAGGI "SERIE/D" (BREVETTATO)

ANTI BREAK-IN FIXING SYSTEM FOR FIXING "SERIE/D" (PATENTED)

SYSTÈME DE FIXATION ANTI EFFRACTION POUR FIXATION "SERIE/D" (BREVETE)

BEFESTIGUNGSSET DIEBSTAHSICHER FÜR BEFESTIGUNGEN "SERIE/D" (PATENTIERT)

SISTEMA DE FIJACIÓN ANTISABOTAJE PARA FIJACIONES "SERIE/D" (BREVETADO)

ANTIVANDALISMEBEVESTIGING VOOR BEVESTIGING "SERIE/D" (GEBREVETTEERD)

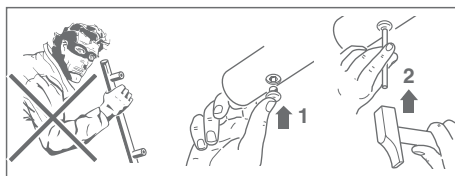



PATENT N° VI2004A000149

ART.	B	Ø
200C-001	1250	35
200C-001/A		

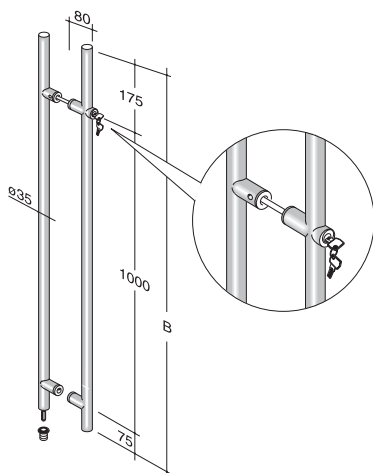

ART.	B	Ø
200C-002	1250	35
200C-002/A		

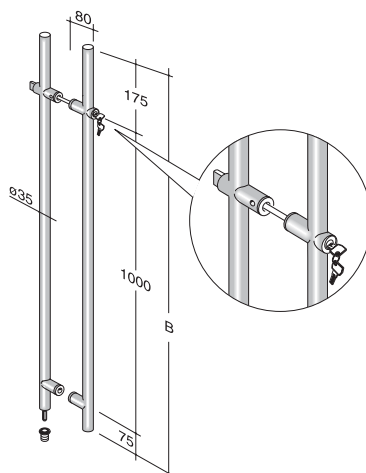

ART.	A	B	Ø
200C-003	1050	2200	35
200C-003/A			

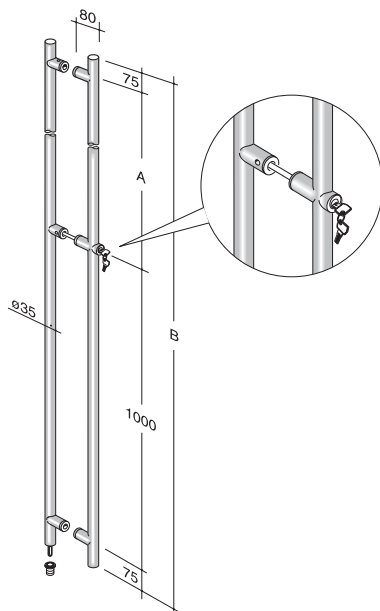

ART.	A	B	Ø
200C-004	1050	2200	35
200C-004/A			

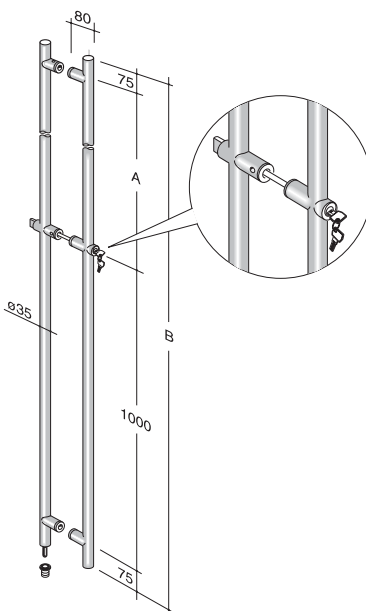



ART.	A	B	Ø
200C-005	1050	2200	35
200C-005/A			

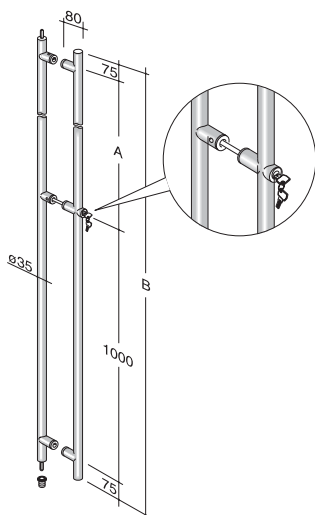

ART.	A	B	Ø
200C-006	1050	2200	35
200C-006/A			

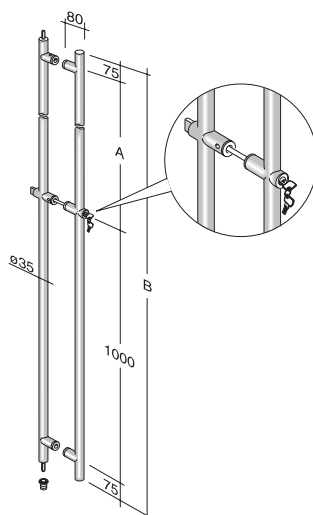

ART.	A	B	Ø
200C-007	1050	2200	35
200C-007/A			

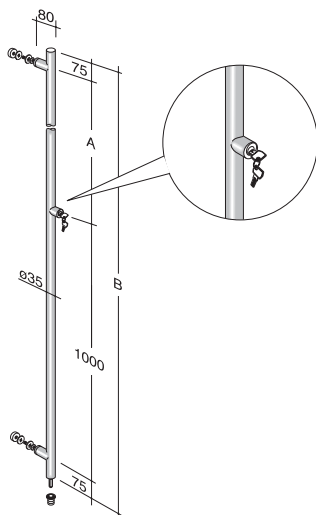

ART.	A	B	Ø
200C-008	1050	2200	35
200C-008/A			

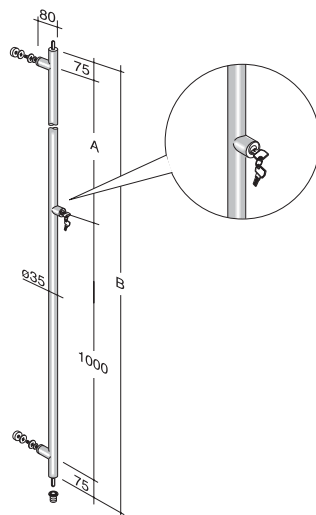



ART.	A	B	Ø
200C-009	1050	2200	35
200C-009/A			

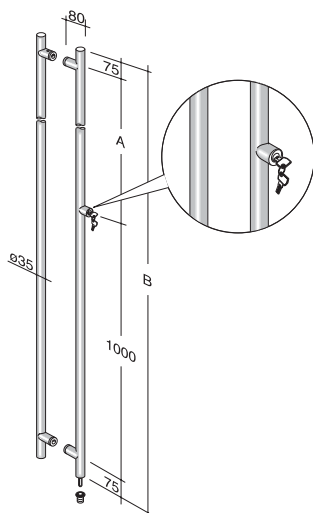

ART.	A	B	Ø
200C-010	1050	2200	35
200C-010/A			

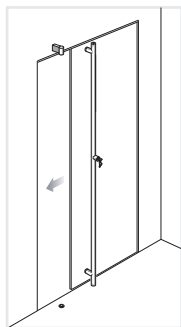
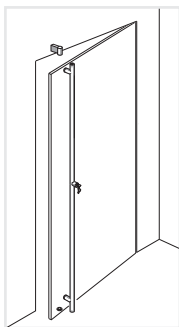
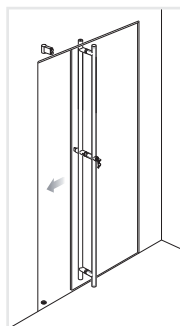
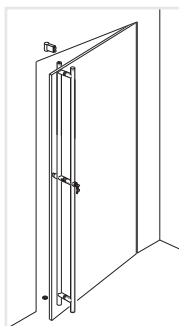
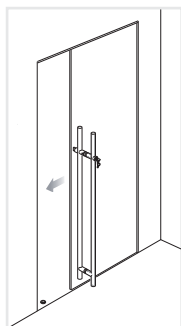
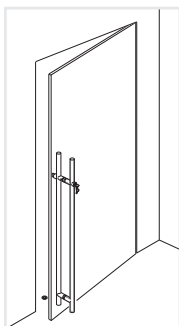
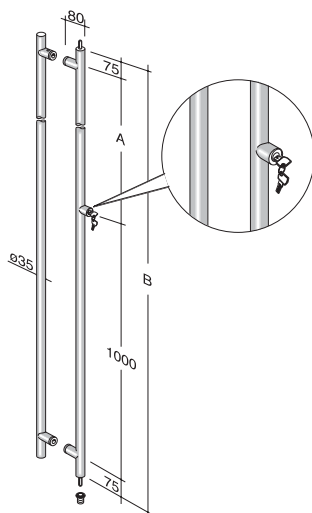



PATENT N° VI2005A000063



ART.	B	Ø
200C-Y-001	1250	35
200C-Y-001/A		

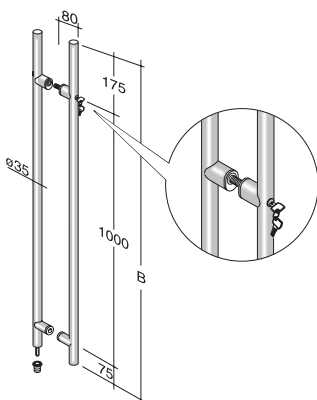

ART.	B	Ø
200C-Y-002	1250	35
200C-Y-002/A		

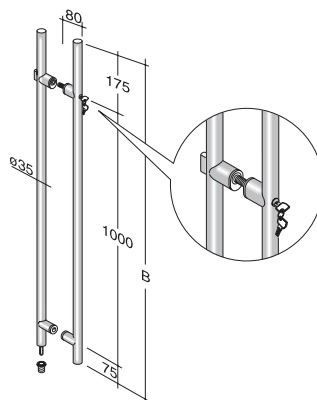

ART.	A	B	Ø
200C-Y-003	1050	2200	35
200C-Y-003/A			

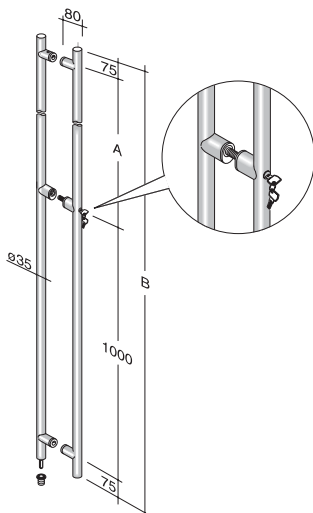

ART.	A	B	Ø
200C-Y-004	1050	2200	35
200C-Y-004/A			

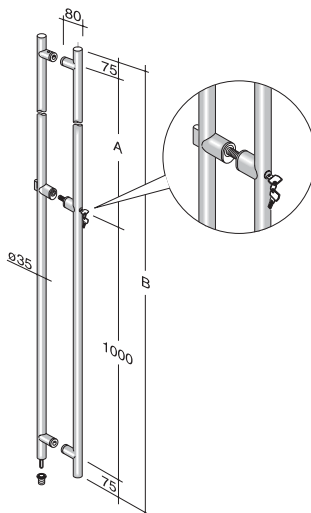



ART.	A	B	Ø
200C-Y-005	1050	2200	35
200C-Y-005/A			

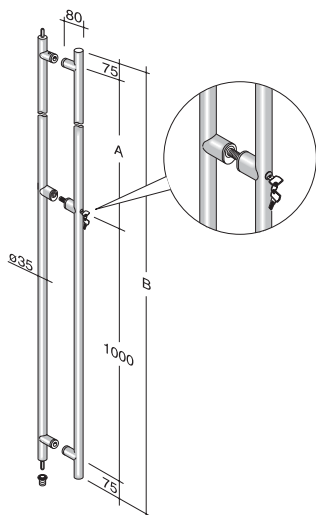

ART.	A	B	Ø
200C-Y-006	1050	2200	35
200C-Y-006/A			

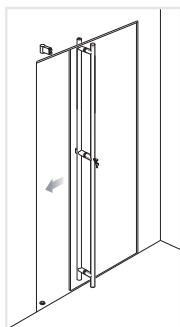
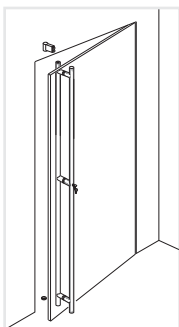
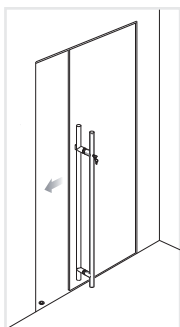
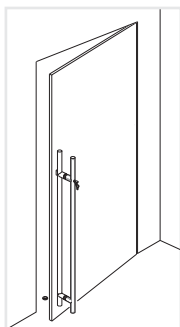
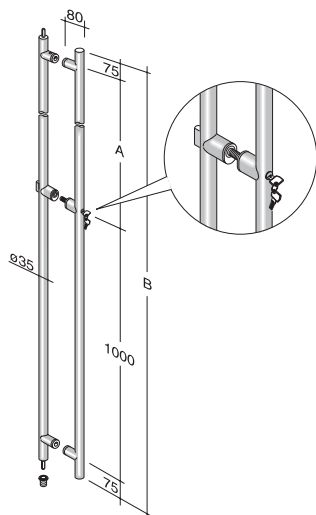



ART.	A
200C-YE-001	1000

ART.	A
200C-YE-002	1000

PATENT N° V12005A000144
N° V120050000004

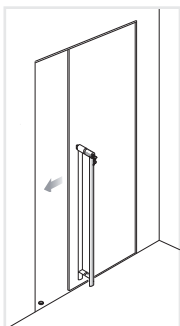
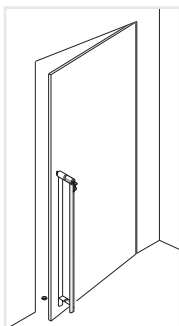
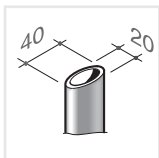
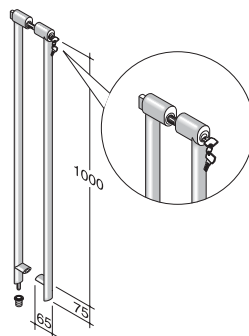
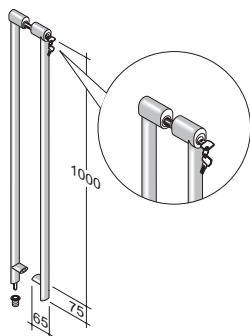



PATENT N° VI2005A000054



ART.	B	Ø
200C-V-001	1150	25
200C-V-001/A		

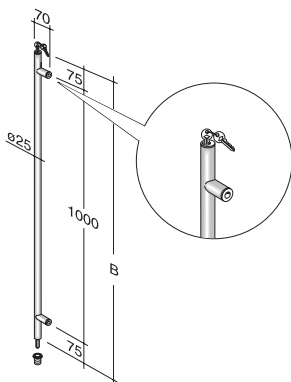

ART.	B	Ø
200C-V-001/D	1150	25
200C-V-001/D/A		

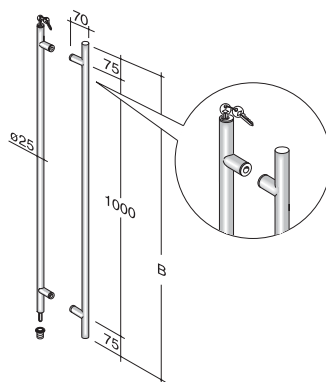

ART.	B	Ø
200C-V-002	1150	30
200C-V-002/A		

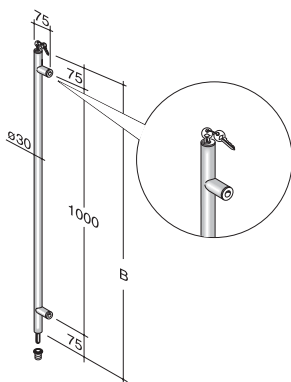

ART.	B	Ø
200C-V-002/D	1150	30
200C-V-002/D/A		

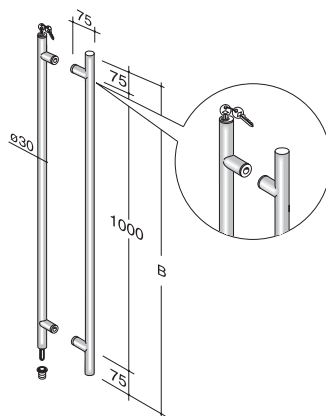



ART.	B	Ø
200C-V-003	1150	35
200C-V-003/A		

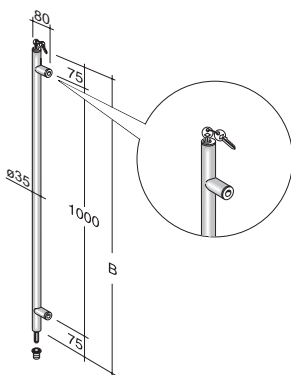

ART.	B	Ø
200C-V-003/D	1150	35
200C-V-003/D/A		

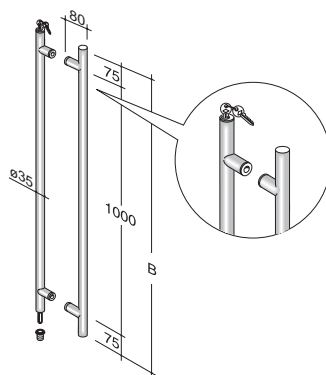

ART.	B	Ø
200C-V-001.PM	1165	25

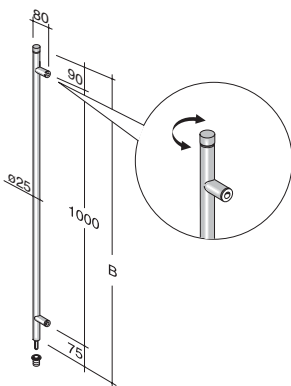

ART.	B	Ø
200C-V-001.PM/D	1165	25

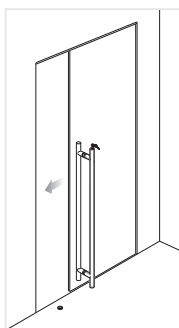
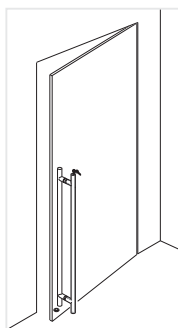
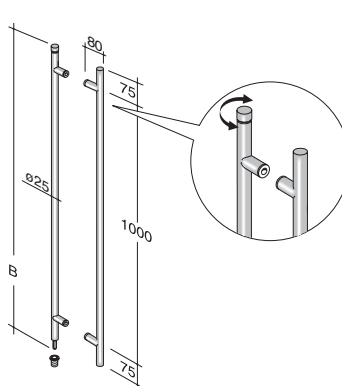

FISSAGGI SERIE/D
FIXINGS SERIES/D
FIXATIONS SERIE/D

BEFESTIGUNGEN SERIE/D
FIJACIONES SERIE/D
BEVESTIGING SERIE/D

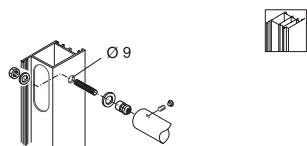

ART. 610/D-INOX

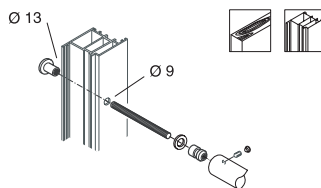

ART. 1110/D-INOX

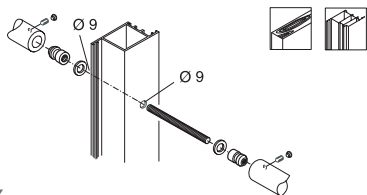

ART. 710/D-INOX

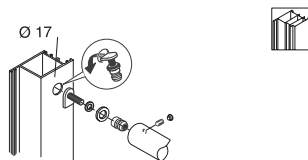

ART. 1210/D-INOX

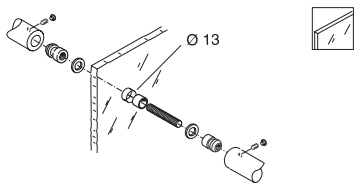

ART. 810/D-INOX

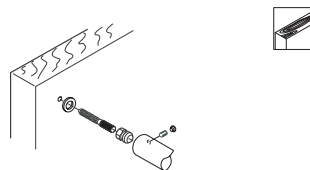

ART. 1310/D-INOX

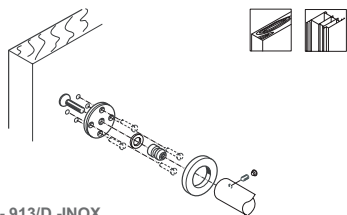

ART. 911/D - 912/D - 913/D -INOX

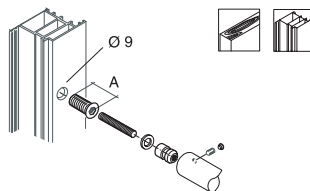

ART. 1410/D-INOX A=33 mm
ART. 1410/DL-INOX A=50 mm

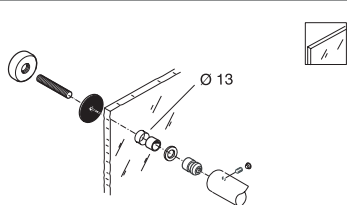

ART. 1011/D - 1012/D - 1013/D -INOX

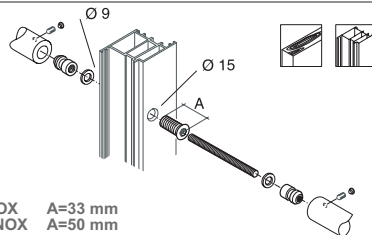

ART. 1510/D-INOX A=33 mm
ART. 1510/DL-INOX A=50 mm

LEGENDA - KEY TO SYMBOL - LÉGENDE - ZEICHENERKLÄRUNG - LEYENDA - LEGENDE

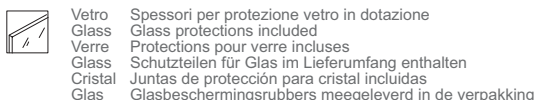

PROGRAMMA K-LOCK

INTERASSI E DIAMETRI FORI
 HOLES CENTER-TO-CENTER SIZES AND DIAMETRES
 ENTRE-AXES ET DIAMÈTRES DES TROUS

ACHSMASS UND DURCHMESSER FÜR DIE BÖHRUNGEN
 DISTINCIA ENTRE EJES Y DIAMETROS DE LOS ORIFICIOS
 ASMATEN EN DIAMETER BORINGEN

- 200C**
 200C-001
 200C-002
200CY
 200C-Y-001
 200C-Y-002
200C-YE
 200C-YE-001
 200C-YE-002

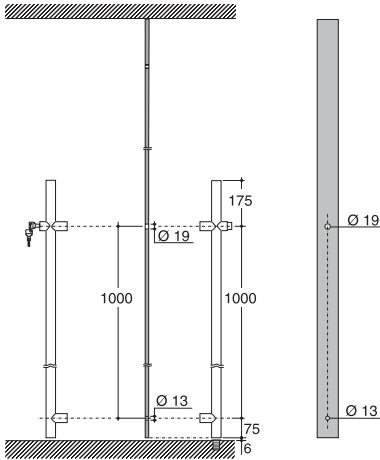

- 200C**
 200C-003
 200C-004
 200C-005
 200C-006
200C-Y
 200C-Y-003
 200C-Y-004
 200C-Y-005
 200C-Y-006

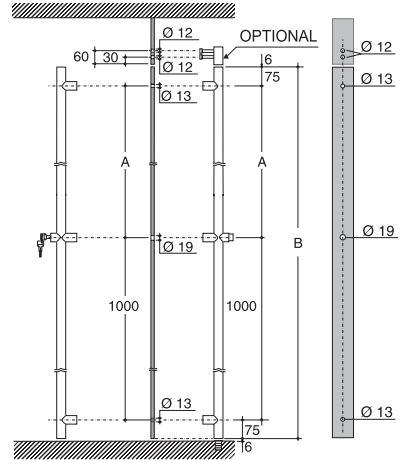

- 200C**
 200C-007
 200C-008
 200C-009
 200C-010

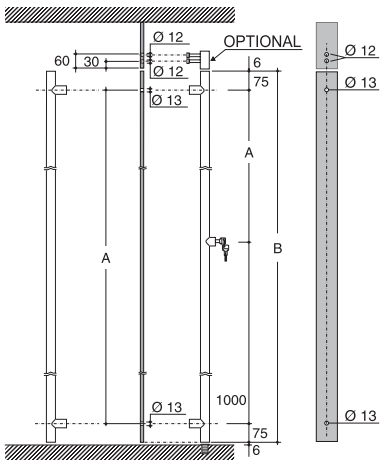

PROGRAMMA K-LOCK

Pozzetto antipolvere
 Dust-free floor socket
 Gâche anti-poussière
 Antistaub Bodenbuchse
 Cerradura embutida antipolvo
 Vloerpot met anti-stofbescherming

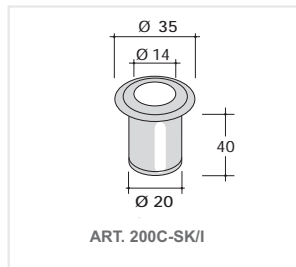
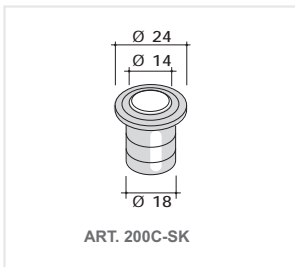

Incontro superiore
 Striker
 Gâche
 Zapfenband – Oberteil
 Set de montaje pasante para cristal
 Bovenlichtsluitstuk

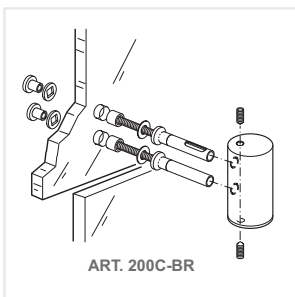

Rotazione della chiave
 Rotation of the key
 Rotation de la clé
 Drehungsrichtung des Schlüssels
 Sentido de giro de la llave
 Draairichting van de sleutel

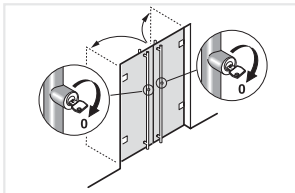

Standard
 Standard
 Standard
 Standard
 Estándar
 Standaard

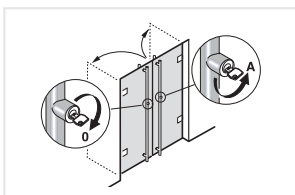

A richiesta
 On request
 À la demande
 Auf Anfrage
 A petición
 Op aanvraag

Puntale di chiusura
 Steel dead bolt
 Pivot
 Schliessanker
 Varilla
 Ondoorzaagbare sluitstang

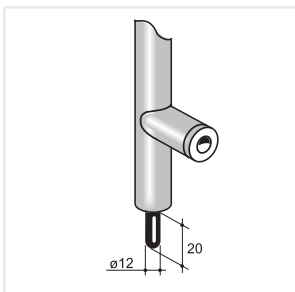

PROGRAMMA K-LOCK

Impianti speciali su richiesta

Special applications on request

Poignées spéciales sur demande

 Auf Anfrage können Master-Schliessanlagen
gemäss KA-MK-GMK Systemen
angefertigt werden

Manillones especiales a petición del cliente

Speciale sluitplannen op aanvraag

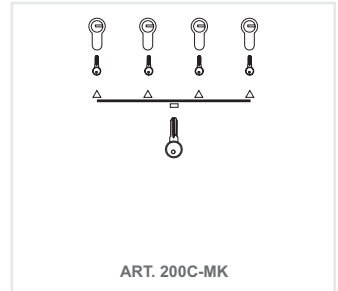
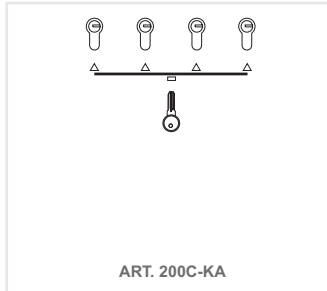
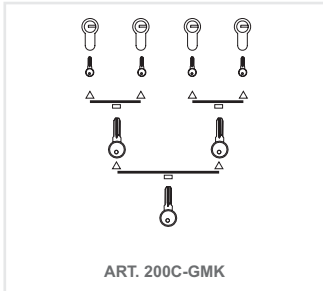

Cilindro a profilo europeo standard

Standard euro profile cylinder

Cylindre avec profil européen standard

Standard europäischen Profilzylinder

Cilindro de perfil europeo estándar

Cylinder met standaard europrofiel

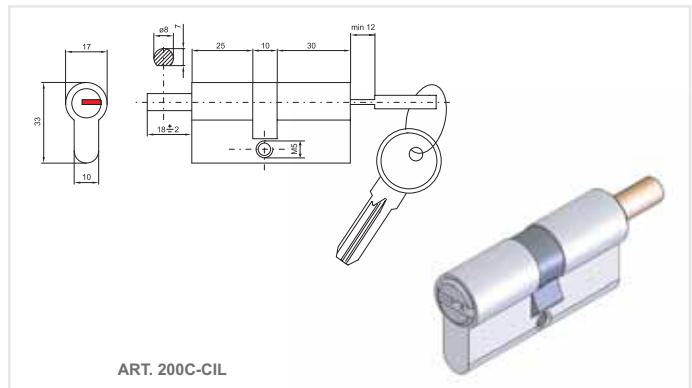

Cilindro a profilo europeo a richiesta

Euro profile cylinder on request

Cylindre avec profil européen sur demande

Europäischen Profilzylinder auf Anfrage

Cilindro de perfil europeo a petición del cliente

Cylinder met europrofiel op aanvraag

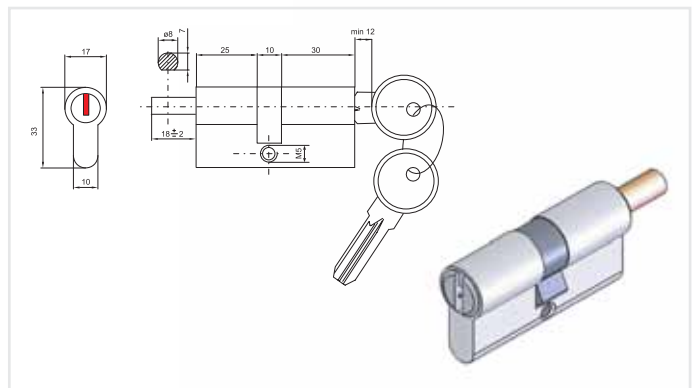



ITALIANO

PROGRAMMA 300

Maniglioni, maniglie e accessori in nylon in granulo colorato. Non si altera se esposto alla luce, alle intemperie ed in zona di mare. Mantiene costante resistenza meccanica in un intervallo di temperatura compreso tra -40°C e +90°C. Rigorosamente made in Italy. Il Programma 300 usa fissaggi che permettono il montaggio singolarmente o in coppia di tutti i modelli su qualunque tipologia di materiale (Legno, Metallo, PVC e Vetro). Maniglioni speciali a richiesta (art.xxx/A).

Colori standard: ● ○ ●

Colori a richiesta: ● ● ● ● ●

ENGLISH

PROGRAMMA 300

Pull handles, lever handles and accessories in through coloured polyamide. The polyamide remains unaffected by exposure to bad weather, light and sea air; maintaining its mechanical strength in temperatures varying between -40°C and +90°C. Precision manufactured in Italy. The Programma 300 fixings permit simple or back to back installation on all models and have been designed to fit any type of material (wood, PVC, metal, glass). Special pull handles on request (art.xxx/A).

Standard colours: ● ○ ●

Colours by request: ● ● ● ● ●

FRANCAIS

PROGRAMMA 300

Bequilles de tirage, poignées et articles de finition en nylon polyamid coloré. Le nylon ne s'altère pas s'il est exposé à la lumière, aux intempéries et dans les régions de mer. Il garde une constante résistance mécanique avec une température comprise entre -40°C et +90°C. Exclusivement made in Italy. Les fixations du Programma 300 peuvent être montées seules ou par paire sur tous les modèles et sur tout type de portes (bois, PVC, métal et verre). Poignées de tirage spéciales sur demande (art.xxx/A).

Couleurs de production: ● ○ ●

Couleurs sur demande: ● ● ● ● ●

DEUTSCH

PROGRAMMA 300

Stoßgriffen, Türdrücker und Baubeschläge aus durchgefärbtem Nylon. Gute Widerstandsfähigkeit gegen Licht, Witterung und Salzatmosphäre. Behält eine dauerhafte mechanische Beständigkeit in Temperaturen zwischen -40°C und +90°C. Made in Italy. Das Programma 300 ermöglicht entweder eine Einzel- sowie eine Paarweisebefestigung auf Türen und Sonderkonstruktionen aller Art (Holz, Kunststoff, Metall, Glas, Türrahmen aus Aluminium, usw.). Stoßgriffen mit einem Sondermass auf Anfrage lieferbar (art.xxx/A).

Standard Farbkarte: ● ○ ●

Farben auf Anfrage lieferbar: ● ● ● ● ●

ESPAÑOL

PROGRAMMA 300

Manillones, manillas y complementos en nylon en granos colorados. El nylon no sufre alteraciones en caso de exposición a la luz, intemperies o en zonas de mar. Mantiene constante la resistencia mecánica en un intervalo de temperatura entre los -40°C y +90°C. Rigurosamente hecho en Italia. Las fijaciones del Programma 300 pueden montarse individualmente o a juego de tutti i modelli en puertas de cualquier tipologia (madera, metal, PVC y cristal). Manillones especiales bajo pedido (art.xxx/A).

Colores estándar: ● ○ ●

Colores requeridos: ● ● ● ● ●

NEDERLANDS

PROGRAMMA 300

Deurgrepen, deurkrukken en accessoires in nylon uit in de massa gekleurde korrel. Onveranderlijk zelfs indien blootgesteld aan licht, alle weersomstandigheden en in zeeklimaat. Behoudt altijd zijn mechanische weerstand in een temperatuur gaande van -40°C tot en met +90°C. Uitsluitend gefabriceerd in Italië. Het Programma 300 gebruikt bevestigingen die het mogelijk maken om iedere greep zowel enkel als per paar te bevestigen op elk materiaal (Hout, Metaal, PVC of glas). Deurgrepen op maat op aanvraag (art. xxx/A).

Standardkleuren: ● ○ ●

Kleuren op aanvraag: ● ● ● ● ●

PROGRAMMA 300
ITALIANO

Specifiche d'ordine	Colore	Confezioni standard	
Per tutti gli articoli:	Standard:	Maniglioni	2 Pezzi
Codice articolo	Nero	Maniglie	10 Coppie
Colore	Bianco	Chiusini	10 Pezzi
	Rosso	Dreh-kipp	10 Pezzi
		Fermaporta	10 Pezzi
Per i maniglioni:	A richiesta:		
Codice articolo	Giallo		
Colore	Verde		
Tipo di fissaggio	Blu		
	Marrone		
	Grigio		

Fissaggi Pagina 117
Pagina 118

ENGLISH

Order specifics	Colour	Standard Packing	
For all articles:	Standard production:	Pull handles	2 Pieces
Article code	Black	Lever handles	10 Pairs
Colour	White	Snib indicators	10 Pieces
	Red	Dreh-kipp	10 Pieces
		Door stop	10 Pieces
For pull handles:	Upon request:		
Article code	Yellow		
Colour	Green		
Type of fixing	Blue		
	Brown		
	Grey		

Fixings Page 117
Page 118

FRANCAIS

Caractéristiques de la commande	Couleur	Emballage standard	
Pour tous les articles:	Production standard:	Poignées	2 Pièces
Code article	Noir	Béquilles	10 Paires
Couleur	Blanc	Verrous	10 Pièces
	Rouge	Dreh-kipp	10 Pièces
		Butoir	10 Pièces
Pour poignées:	À la demande:		
Code article	Jaune		
Couleur	Vert		
Type de fixation	Bleu		
	Marron		
	Gris		

Fixation Page 117
Page 118

DEUTSCH

Bestellangabe	Farbe	Packeinheit	
Für alle Artikel:	Standard farbtafel:	Stossgriffe	2 Stück
Artikelnummer	Schwarz	Türdrücker	10 Paar
Farbe	Weiss	Baderosetten	10 Stück
	Rot	Fenstergriffe	10 Stück
		Türstopper	10 Stück
Für die Stossgriffen:	Farben auf anfrage:		
Artikelnummer	Gelb		
Farbe	Grün		
Befestigungsart	Blau		
	Braun		
	Grau		

Befestigungen Seite 117
Seite 118

ESPAÑOL

Características del pedido	Color	Confección estándar	
Para todos los artículos:	Producción estándar:	Manillones	2 Piezas
Código artículo	Negro	Manillas	10 Juegos
Color	Blanco	Cierres	10 Piezas
	Rojo	Dreh-kipp	10 Piezas
		Tope de puerta	10 Piezas
Para manillones:	Bajo pedido:		
Código artículo	Amarillo		
Color	Verde		
Tipo de fijación	Azul		
	Marron		
	Gris		

Fijaciones Pagina 117
Pagina 118

NEDERLANDS

Besteidetails	Kleur	Standaardverpakking	
Voor alle artikelen:	Standaard-productie:	Deurgrepen	2 Stuks
Artikelcode	Zwart	Deurkrukken	10 Paar
Kleur	Wit	Draaikiep	10 Stuks
	Rood	WC-Vergrendelingen	10 Stuks
		Deurstop	10 Stuks
Voor de deurgrepen:	Op aanvraag:		
Artikelcode	Gell		
Kleur	Groen		
Bevestigingstype	Blauw		
	Bruin		
	Grijs		

Bevestiging Pagina 117
Pagina 118

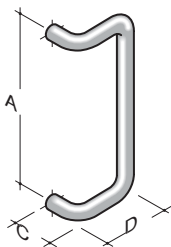

ART.	A	C	D	Ø
307	230	70	110	30
321	250	70	115	30
322	300	70	120	30
308	350	70	120	35
311	650	70	120	35
311/A				

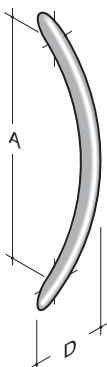

ART.	A	D	Ø
335	430	125	35
336	500	79	35

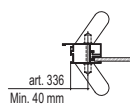
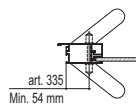

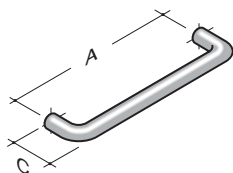

ART.	A	C	Ø
305	230	70	30
319	250	70	30
320	300	70	30
306	350	70	35
310	650	70	35
310/A			

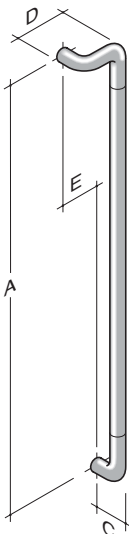

ART.	A	C	D	E	Ø
313	950	70	120	85	35
313-1200	1200	70	120	85	35
313/A					

ART.	A	C	D	Ø
330	300	70	160	30
316	425	70	230	35

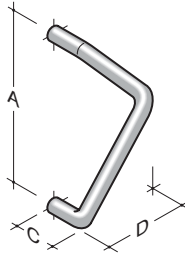
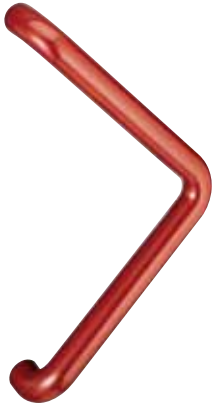

ART.	A	C	D	Ø
309	230	70	190	30
329	250	70	210	30
318	300	70	265	35

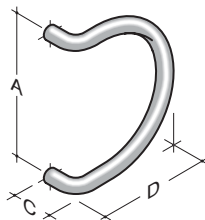

ART.	A	C	D	Ø
331	350	80	115	35

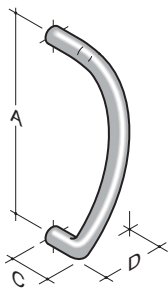

ART.	A	C	D	Ø
332	350	72	105	35

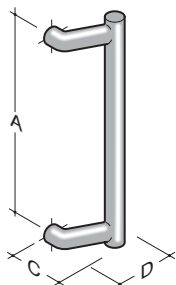

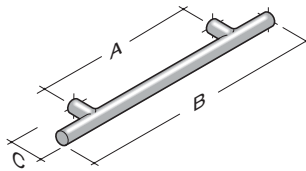
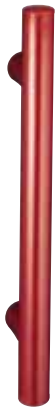

ART.	A	B	C	Ø
314	350	520	75	35
315	550	720	75	35
315/A				

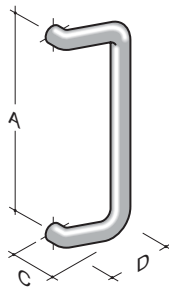

ART.	A	C	D	Ø
308I	350	80	110	35

ART.	A	B	C	D
358	320	420	72	210

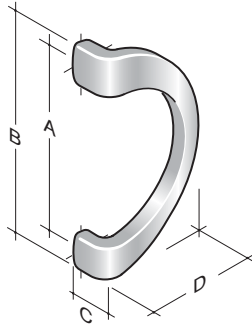

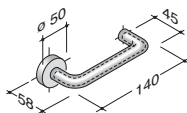

ART. 326

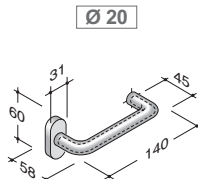

ART. 328

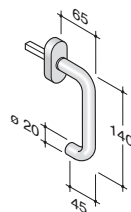

ART. 327

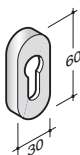

ART. 328Y

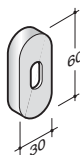

ART. 328P

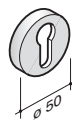

ART. 326Y

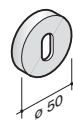

ART. 326P

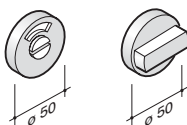

ART. 324

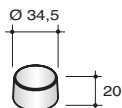

ART. 340

- Colori ● ○
- Colours ● ○
- Couleurs ● ○
- Farben ● ○
- Colores ● ○
- Kleuren ● ○

FISSAGGI SERIE NYLON
FIXINGS SERIES NYLON
FIXATIONS SERIE NYLON

BEFESTIGUNGEN SERIE NYLON
FIJACIONES SERIE NYLON
BEVESTIGING SERIE NYLON

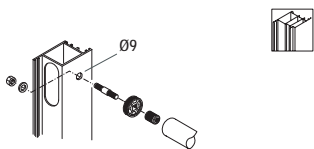

ART. 602 = Ø30, 603 = Ø35

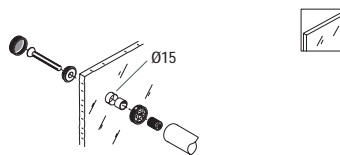

ART. 1002 = Ø30, 1003 = Ø35

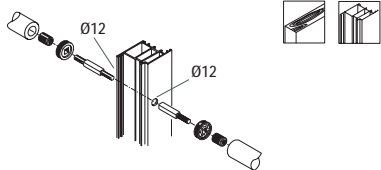

ART. 702 = Ø30, 703 = Ø35

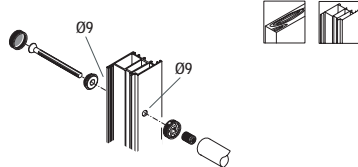

ART. 1102 = Ø30, 1103 = Ø35

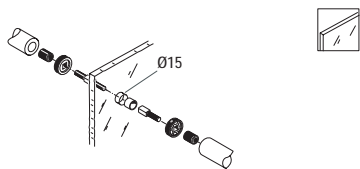

ART. 802 = Ø30, 803 = Ø35

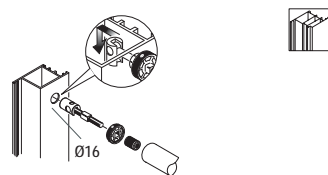

ART. 1202 = Ø30, 1203 = Ø35

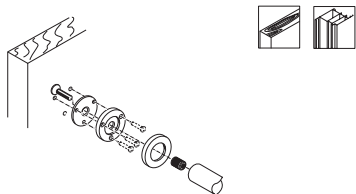

ART. 902 = Ø30, 903 = Ø35

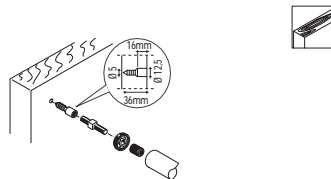

ART. 1302 = Ø30, 1303 = Ø35

LEGENDA - KEY TO SYMBOL - LÉGENDE - ZEICHENERKLÄRUNG - LEYENDA - LEGENDE

 Legno
Wood
Holz
Bois
Madera
Hout

 Alluminio / Pvc
Aluminium / Pvc
Aluminium / Pvc
Aluminium / Pvc
Aluminium / Pvc
Aluminium / Pvc

 Vetro
Glass
Verre
Glass
Cristal
Glas

PROGRAMMA 300

FISSAGGI SERIE /D-NYLON
 FIXINGS SERIES /D-NYLON
 FIXATIONS SERIE /D-NYLON

Art. 335 - 336 - 358
 Art. 335 - 336 - 358
 Art. 335 - 336 - 358

BEFESTIGUNGEN SERIE /D-NYLON
 FIJACIONES SERIE /D-NYLON
 BEVESTIGING SERIE /D-NYLON

Art. 335 - 336 - 358
 Art. 335 - 336 - 358
 Art. 335 - 336 - 358

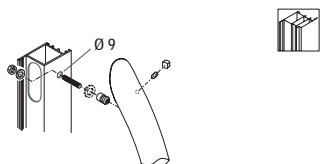
ART. 610/D-NYLON

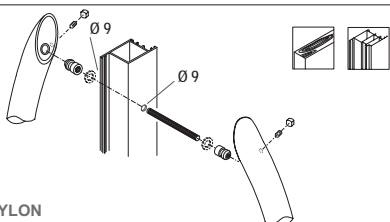
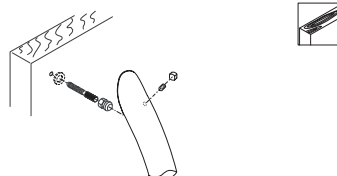
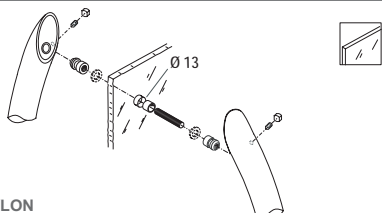
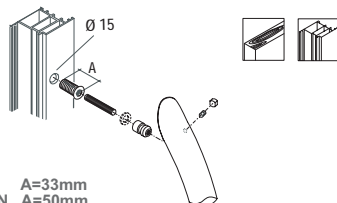
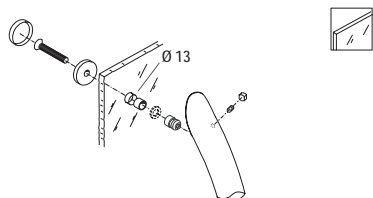
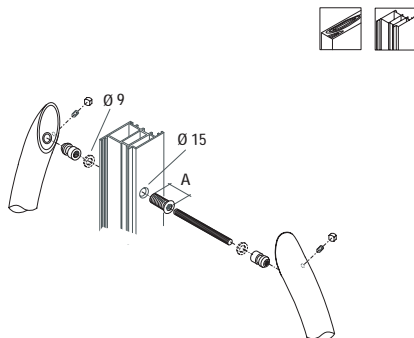
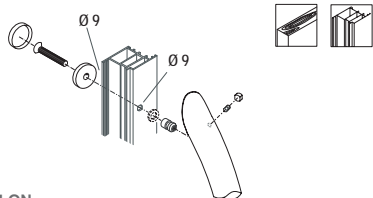
ART. 1210/D-NYLON

ART. 710/D-NYLON

ART. 1310/D-NYLON

ART. 810/D-NYLON

ART. 1410/D-NYLON A=33mm
ART. 1410/DL-NYLON A=50mm

ART. 1010/D-NYLON

ART. 1510/D-NYLON A=33mm
ART. 1510/DL-NYLON A=50mm

ART. 1110/D-NYLON
LEGENDA - KEY TO SYMBOL - LÉGENDE - ZEICHENERKLÄRUNG - LEYENDA - LEGENDE

Legno
 Wood
 Holz
 Bois
 Madera
 Hout



Alluminio / Pvc
 Aluminium / Pvc
 Aluminium / Pvc
 Aluminium / Pvc
 Aluminium / Pvc
 Aluminium / Pvc



Vetro
 Glass
 Verre
 Glass
 Cristal
 Glas

PROGRAMMA M18

ITALIANO
PROGRAMMA M18

Maniglioni in alluminio estruso. Alluminio anticordal lega UNI 3569 HB 55: garanzia assoluta di robustezza e durata. Rigorosamente made in Italy.

Il Programma M18 usa fissaggi che permettono il montaggio singolarmente o in coppia di tutti i modelli su qualunque tipologia di materiale (Legno, Metallo, PVC e Vetro).

Finitura standard: nero - bianco (RAL.1013) - bianco (RAL.9010) - ossidato argento - grezzo.

Finitura a richiesta: bronzo - elox - rosso - giallo.

Maniglioni speciali a richiesta (art.xxx/A).

ENGLISH
PROGRAMMA M18

Pull handles in extruded aluminium. Aluminium alloy UNI 3569 HB 55: for strength, reliability and long life. Precision manufactured in Italy.

The Programma M18 fixings permit simple or back to back installation on all models and have been designed to fit any type of material (wood, PVC, metal, glass).

Standard finishing: black - white (RAL.1013) - white (RAL.9010) - anodized silver - self coloured.

Finishing by request: bronze - elox pba - red - yellow.

Special pull handles on request (art.xxx/A).

FRANCAIS
PROGRAMMA M18

Poignées de tirage en aluminium extrudé anti-corrosion alliage UNI 3569 HB 55: garantie totale de robustesse et de longévité.

Exclusivement made in Italy. Les fixations du Programma M18 peuvent être montées seules ou par paire sur tous les modèles et sur tout types de portes (bois, PVC, métal et vitre).

Finition standard: noir - blanc (RAL.1013) - blanc (RAL.9010) - argent - brut.

Finition sur demande: alu bronze - elox pba - rouge - jaune.

Poignées de tirage spéciales sur demande (art.xxx/A).

DEUTSCH
PROGRAMMA M18

Stossgriffe aus Aluminium. Aluminium aus Legierung UNI 3569 HB 55. Die Widerstandfähigkeit und Dauerhaftigkeit ist garantiert. Made in Italy.

Das Programma M18 ermöglicht entweder eine Einzel- sowie eine Paarweisebefestigung auf Türen und Sonderkonstruktionen aller Art (Holz, Kunststoff, Metall, Glas, Türrahmen aus Aluminium, usw). Standardausführung: schwarz - weiss (RAL.1013) - weiss (RAL. 9010) - eloxierte silber - roh.

Ausführungen auf anfrage: bronze, elox pba, rot, gelb.

Stossgriffen mit einem Sondermass auf Anfrage lieferbar (art.xxx/A).

ESPAÑOL
PROGRAMMA M18

Manillones en aluminio extruido. Aluminio anticordal aleación UNI 3569 HB 55: garantía absoluta de solidez y duración. Rigurosamente hecho en Italia.

Las fijaciones del Programma M18 pueden montarse individualmente o a juego de tutti i modelli en puertas de cualquier tipología (madera, metal, PVC y cristal).

Acabados en serie: negro - blanco (RAL.1013) - blanco (RAL. 9005) - oxidado plata - no acabado.

Acabados bajo petición: bronce - elox pba - rojo - amarillo.

Manillones especiales bajo pedido (art.xxx/A).

NEDERLANDS
PROGRAMMA M18

Deurgrepen in geëxtrudeerd aluminium. Aluminium in legering volgens UNI 3569 HB 55: een absolute garantie van robuustheid op lange termijn. Uitsluitend gefabriceerd in Italië.

Het Programma M18 gebruikt bevestigingen die het mogelijk maken om iedere greep zowel enkel als per paar te bevestigen op elk materiaal (Hout, Metaal, PVC of glas).

Standaardafwerking: zwart - wit (RAL.1013) - wit (RAL. 9005) - zilver geanodiseerd - bruu.

Afwerking op aanvraag: brons geanodiseerd - pba gelakt - rood - geel.

Deurgrepen op maat op aanvraag (art. xxx/A).

ITALIANO

Specifiche d'ordine	Finiture	Confezioni standard	
Per tutti gli articoli: Codice articolo Tipologia di finitura Tipo di fissaggio	Standard: Nero Bianco (1013) Bianco (9010) Ossidato argento Grezzo A richiesta: Bronzo Elox Rosso Giallo	Maniglioni	2 Pezzi

Fissaggi
Pagina 126
ENGLISH

Order specifics	Finishes	Standard Packing	
For all articles: Article code Type of finish Fitting code	Standard production: Black White (1013) White (9010) Anodised silver Unfinished Upon request: Bronze Elox Red Yellow	Pull handles	2 Pieces

Fixings
Page 126
FRANCAIS

Caractéristiques de la commande	Finitions	Emballage standard	
Pour tous les articles: Code article Typologie de finition Code fixation	Production standard: Noir Blanc (1013) Blanc (9010) Oxydé argent Brut À la demande: Bronze Elox Rouge Jaune	Poignées	2 Pièces

Fixation
Page 126
DEUTSCH

Bestellangabe	Ausführungen	Packeinheit zstück	
Für alle Artikel: Artikelnummer Ausführung Befestigungsart	Standard farbtafel: Schwartz Weiss (1013) Weiss (9010) Siber eloxiert Roh Farben auf Anfrage: Bronzefarbig Elox Rot Gelb	Stossgriffe	2 Stück

Befestigungen
Seite 126
ESPAÑOL

Características del pedido	Acabados	Confección estándar	
Para todos los artículos: Código artículo Tipo de acabado Código fijación	Producción estándar: Negro Blanco (1013) Blanco (9010) Oxidado plata Bruto Bajo pedido: Bronce Elox Rojo Amarillo	Manillones	2 Piezas

Fijaciones
Página 126
NEDERLANDS

Besteidetails	Afwerkingen	Standaardverpakking	
Voor alle artikelen: Artikelcode Afwerkingstype Bevestigingstype	Standaard-productie: Zwart Wit (1013) Wit (9010) Geanodiseerd zilver Bruut Op aanvraag: Bronz Elox Rood Geel	Deurgrepen	2 Stuks

Bevestiging
Pagina 126

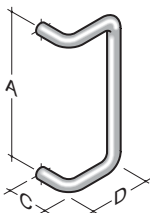
PROGRAMMA M18

ART.	A	C	D	Ø
M18D-230	230	70	120	25
M18D/A				
M18D-230	230	85	145	30
M18D-320	320	85	145	30
M18D/A				
M18D-350	350	85	155	35
M18D-650	650	85	155	35
M18D/A				

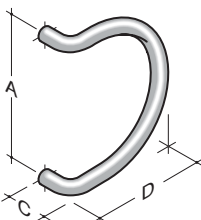

ART.	A	C	D	Ø
M18R-150	150	70	150	25
M18R-170	170	70	170	25
M18R-230	230	85	230	30
M18R-300	300	85	260	30
M18R-350	350	85	300	35

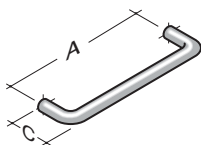
PROGRAMMA M18

ART.	A	C	Ø
M18S-230	230	70	25
M18S/A			
M18S-230	230	85	30
M18S-320	320	85	30
M18S/A			
M18S-350	350	85	35
M18S-650	650	85	35
M18S/A			

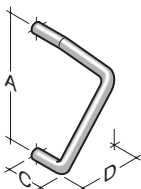

ART.	A	C	D	Ø
M18L-300	300	85	165	30
M18L-425	425	85	225	35

PROGRAMMA M18

ART.	A	C	D	E	Ø
M18Z-950	950	85	155	120	35
M18Z-1200	1200	85	155	120	35
M18Z/A					

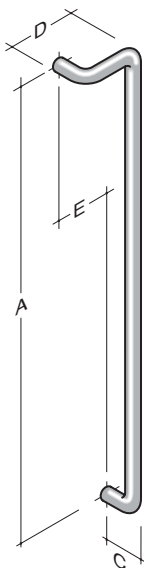

ART.	A	B	C	Ø
M18B-350	350	520	70	35
M18B-550	550	720	70	35
M18B/A				

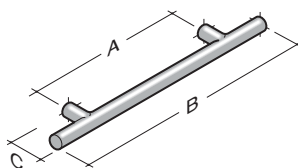

PROGRAMMA M18

ART.	A	C	D	Ø
M18T-350	350	70	220	35

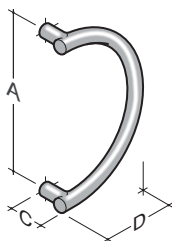

PROGRAMMA M18

FISSAGGI SERIE ALU
FIXINGS SERIES ALU
FIXATIONS SERIE ALU

BEFESTIGUNGEN SERIE ALU
FIJACIONES SERIE ALU
BEVESTIGING SERIE ALU

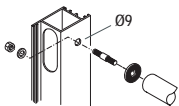

DOTAZIONE A= Ø25, Ø30, Ø35

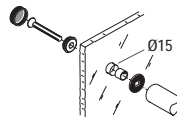

DOTAZIONE E= Ø25, Ø30, Ø35

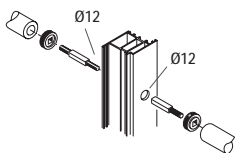
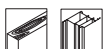

DOTAZIONE B= Ø25, Ø30, Ø35

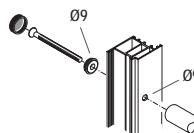

DOTAZIONE F= Ø25, Ø30, Ø35

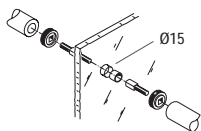

DOTAZIONE C= Ø25, Ø30, Ø35

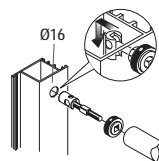

DOTAZIONE G= Ø25, Ø30, Ø35

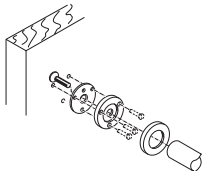
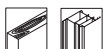

DOTAZIONE D= Ø30, Ø35

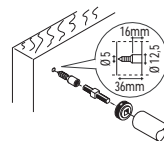

DOTAZIONE H= Ø25, Ø30, Ø35

LEGENDA - KEY TO SYMBOL - LÉGENDE - ZEICHENERKLÄRUNG - LEYENDA - LEGENDE



Legno
Wood
Holz
Bois
Madera
Hout



Alluminio / Pvc
Aluminium / Pvc
Aluminium / Pvc
Aluminium / Pvc
Aluminium / Pvc
Aluminium / Pvc



Vetro
Glass
Verre
Glass
Cristal
Glas

**ITALIANO****PROGRAMMA 100**

Maniglioni in ottone lucidato e protetto da una vernice trasparente.
Rigorosamente made in Italy.

Il Programma 100 usa fissaggi che permettono il montaggio singolarmente o in coppia di tutti i modelli su qualunque tipologia di materiale (Legno, Metallo, PVC e Vetro).

Finitura standard: ottone lucidato e verniciato.

Maniglioni speciali a richiesta (art.xxx/A).

DEUTSCH**PROGRAMMA 100**

Stossgrieffen aus Messing. Messing hochglanzpoliert geschütz durch einen transparenten Lack. Made in Italy.

Das Programma 100 ermöglicht entweder eine Einzel- sowie eine Paarweisebefestigung auf Türen und Sonderkonstruktionen aller Art (Holz, Kunststoff, Metall, Glas, Türrahmen aus Aluminium, usw.).

Standardausführung: poliert und lackiert.

Stossgrieffen mit einem Sondermass auf Anfrage lieferbar (art.xxx/A).

ENGLISH**PROGRAMMA 100**

Pull handles in polished brass protected by clear powder coat.

Precision manufactured in Italy.

The Programma 100 fixings permit simple or back to back installation on all models and have been designed to fit any type of material (wood, PVC, metal, glass).

Standard finishing: brass polished and varnished.

Special pull handles on request (art.xxx/A).

ESPAÑOL**PROGRAMMA 100**

Manillones en latón pulido y recubierto de barniz transparente.

Rigurosamente hecho en Italia.

Las fijaciones del Programa 100 pueden montarse individualmente o a juego de tutti i modelli en puertas de cualquier tipología (madera, metal, PVC y cristal).

Acabados en serie: latón brillante y barnizado.

Manillones especiales bajo pedido (art.xxx/A).

FRANCAIS**PROGRAMMA 100**

Poignées de tirage en laiton poli et protégé par un vernis transparent. Exclusivement made in Italy.

Les fixations du Programma 100 peuvent être montées seules ou par paire sur tous les modèles et sur tout types de portes (bois, PVC, métal et verre).

Finition standard: laiton poli et vernis.

Poignées de tirage spéciales sur demande (art.xxx/A).

NEDERLANDS**PROGRAMMA 100**

Deurgrepen in gepolijst messing, beschermd door een onzichtbare vernislaag. Uitsluitend gefabriceerd in Italië.

Het Programma 100 gebruikt bevestigingen die het mogelijk maken om iedere greep zowel enkel als per paar te bevestigen op elk materiaal (Hout, Metaal, PVC of glas).

Standaardafwerking: verniste gepolijste messing.

Deurgrepen op maat op aanvraag (art. xxx/A)

ITALIANO

Specifiche d'ordine	Finiture	Confezioni standard	
---------------------	----------	---------------------	--

Per tutti gli articoli: Ottone Maniglioni 2 Pezzi
 Codice articolo
 Tipo di fissaggio

Fissaggi Pagina 134

ENGLISH

Order specifics	Finishes	Standard Packing	
-----------------	----------	------------------	--

For all articles: Brass Pull handles 2 Pieces
 Article code
 Type of fixing

Fixings Page 134

FRANCAIS

Caractéristiques de la commande	Finitions	Emballage standard	
---------------------------------	-----------	--------------------	--

Pour tous les articles: Laiton Poignées 2 Pièces
 Code article
 Type de fixation

Fixation Page 134

DEUTSCH

Bestellangabe	Ausführungen	Packeinheit zstück	
---------------	--------------	--------------------	--

Für alle Artikel: Messing Stosgriffe 2 Stück
 Artikelnummer
 Befestigungsart

Befestigungen Seite 134

ESPAÑOL

Características del pedido	Acabados	Confección estándar	
----------------------------	----------	---------------------	--

Para todos los artículos: Latón Manillones 2 Piezas
 Código artículo
 Tipo de fijación

Fijaciones Pagina 134

NEDERLANDS

Besteiddetails	Afwerkingen	Standaardverpakking	
----------------	-------------	---------------------	--

Voor alle artikelen: Messing Deurgrepen 2 Stuks
 Artikelcode
 Bevestigingstype

Bevestiging Pagina 134

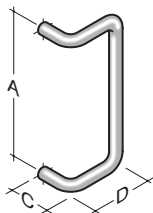

ART.	A	C	D	Ø
133	250	70	120	25
134	300	70	120	25
134/A				
118	230	85	145	30
119	320	85	145	30
119/A				
122	350	85	155	35
139/A				

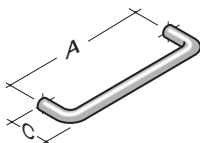

ART.	A	C	Ø
107	200	70	25
131	250	70	25
132/A			
116	230	85	30
117	320	85	30
117/A			
121	350	85	35
138/A			

ART.	A	C	D	Ø
111	150	70	150	25
135	250	70	225	25
120	230	85	230	30
127	300	85	260	30
123	350	85	300	35

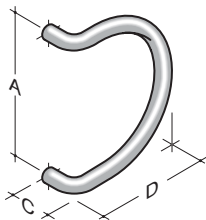

ART.	A	C	D	Ø
124	425	85	225	35

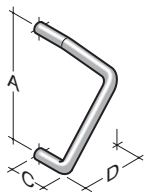

ART.	A	C	D	Ø
137	300	65	190	30
140	350	70	210	35

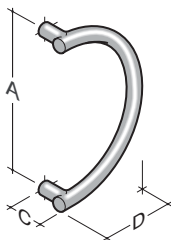

ART.	A	B	D	Ø
129	350	520	70	35
130/A				

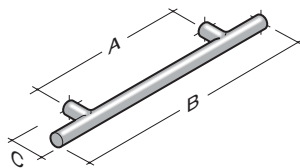

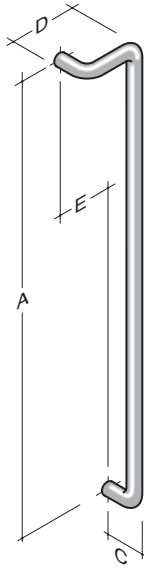

ART.	A	C	D	E	Ø
126	1200	85	155	120	35
126/A					

FISSAGGI SERIE 100
FIXINGS SERIES 100
FIXATIONS SERIE 100

BEFESTIGUNGEN SERIE 100
FIJACIONES SERIE 100
BEVESTIGING SERIE 100

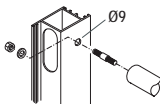

ART. 600-INOX-OTTONE

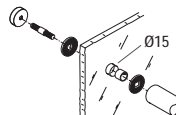

ART. 1001-1002-1003 OTTONE

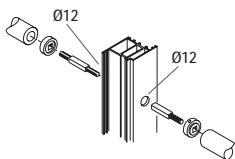

ART. 701-702-703 OTTONE

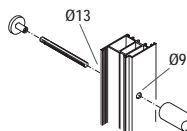

ART. 1100 OTTONE

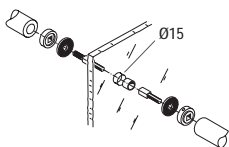

ART. 801-802-803 OTTONE

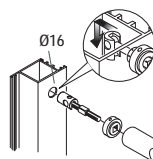

ART. 1201-1202-1203 OTTONE

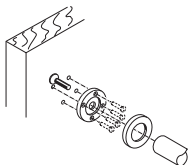
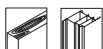

ART. 901-902-903 OTTONE

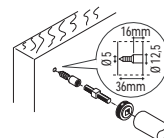

ART. 1301-1302-1303 OTTONE

LEGENDA - KEY TO SYMBOL - LÉGENDE - ZEICHENERKLÄRUNG - LEYENDA - LEGENDE

 Legno
Wood
Holz
Bois
Madera
Hout

 Alluminio / Pvc
Aluminium / Pvc
Aluminium / Pvc
Aluminium / Pvc
Aluminio / Pvc
Aluminium / Pvc

 Vetro
Glass
Verre
Glass
Cristal
Glas

PROGRAMMA PVD



ITALIANO

PROGRAMMA PVD

Maniglioni in inox (PVD): acciaio inossidabile AISI 316L rivestito di purissimo Nitruro di Zirconio (ZrN).

Massima resistenza alla corrosione. Rigorosamente made in Italy. Il Programma PVD usa fissaggi che permettono il montaggio singolarmente o in coppia di tutti i modelli su qualunque tipologia di materiale (Legno, Metallo, PVC e Vetro).

Finitura standard: acciaio inox con trattamento PVD.

DEUTSCH

PROGRAMMA PVD

Stahl Werkstoff 1.4404/Messing (Physical Vapor Deposition) Stahl Werkstoff 1.4404/Messing beschichtet mit Zirkonium Nitrid. Abrieb und Korrosionsbeständigkeit.

Made in Italy.

Das Programma PVD ermöglicht entweder eine Einzel- sowie eine Paarweisebefestigung auf Türen und Sonderkonstruktionen aller Art (Holz, Kunststoff, Metall, Glas, Türrahmen aus Aluminium, usw).

Standardausführung: Edelstahl mit Zirkoniumbeschichtung.

ENGLISH

PROGRAMMA PVD

Steel brass (PVD): stainless steel AISI 316L coated with ultra pure Zirconium Nitride (ZrN).

Maximum resistance to corrosion. Precision manufactured in Italy. The Programma PVD fixings permit simple or back to back installation on all models and have been designed to fit any type of material (wood, PVC, metal, glass).

Standard finishing: stainless steel with PVD coating.

ESPAÑOL

PROGRAMMA PVD

Inox (PVD): acero inoxidable AISI 316L revestido con purísimo Nitruro de Zirconio (ZrN). Máxima resistencia a la corrosión. Rigurosamente hecho en Italia.

Las fijaciones del Programa PVD pueden montarse individualmente o a juego de tutti i modelli in puertas de cualquier tipología (madera, metal, PVC y cristal).

Acabados en serie: acero inoxidable con tratamiento PVD.

FRANCAIS

PROGRAMMA PVD

Inox (PVD): acier inoxydable AISI 316L revêtu de Nitruro de Zirconium (ZrN) très pur.

Résistance maximum à la corrosion. Exclusivement made in Italy. Les fixations du Programma PVD peuvent être montées seules ou par paire sur tous les modèles et sur tout type de portes (bois, PVC, métal et verre).

Finition standard: acier inoxydable avec traitement PVD.

NEDERLANDS

PROGRAMMA PVD

Inox (PVD): roestvast staal AISI 316L behandeld met de allerzuiverste zirkoniumstikstof (ZrN).

Allerhoogste roestweerstand. Uitsluitend gefabriceerd in Italië.

Het Programma PVD gebruikt bevestigingen die het mogelijk maken om iedere greep zowel enkel als per paar te bevestigen op elk materiaal (Hout, Metaal, PVC of glas).

Standaardafwerking: roestvast staal met PVD behandeling.

PROGRAMMA PVD
ITALIANO

Specifiche d'ordine	Finiture	Confezioni standard	
---------------------	----------	---------------------	--

Per tutti gli articoli: Codice articolo Tipo di fissaggio	Acciaio inox AISI 316L+PVD	Maniglioni	2 Pezzi
---	-------------------------------	------------	---------

Fissaggi Pagina 142

ENGLISH

Order specifics	Finishes	Standard Packing	
-----------------	----------	------------------	--

For all articles: Article code Type of fixing	Stainless steel AISI 316L+PVD	Pull handles	2 Pieces
---	----------------------------------	--------------	----------

Fixings Page 142

FRANCAIS

Caractéristiques de la commande	Finitions	Emballage standard	
---------------------------------	-----------	--------------------	--

Pour tous les articles: Code article Type de fixation	Acier inoxydable AISI 316L+PVD	Poignées	2 Pièces
---	-----------------------------------	----------	----------

Fixation Page 142

DEUTSCH

Bestellangabe	Ausführungen	Packeinheit zstück	
---------------	--------------	--------------------	--

Für alle Artikel: Artikelnummer Befestigungsart	Edelstahl rostfrei 1.4404+PVD	Stossgriffe	2 Stück
---	-------------------------------------	-------------	---------

Befestigungen Seite 142

ESPAÑOL

Características del pedido	Acabados	Confección estándar	
----------------------------	----------	---------------------	--

Para todos los artículos: Código artículo Tipo de fijación	Acero inoxidable AISI 316L+PVD	Manillones	2 Piezas
--	--------------------------------------	------------	----------

Fijaciones Pagina 142

NEDERLANDS

Besteidetails	Afwerkingen	Standaardverpakking	
---------------	-------------	---------------------	--

Voor alle artikelen: Artikelcode Bevestigingstype	Roestvast staal AISI 316L+PVD	Deurgrepen	2 Stuks
---	----------------------------------	------------	---------

Bevestiging Pagina 142

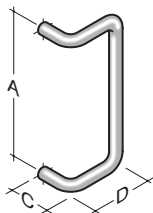
PROGRAMMA PVD

ART.	A	C	D	Ø
207-PVD	200	70	120	25
259-PVD	300	85	145	30
220-PVD	350	85	155	35

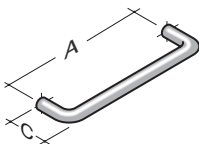

ART.	A	C	Ø
205-PVD	200	70	25
206-PVD	300	85	30
219-PVD	350	85	35

PROGRAMMA PVD

ART.	A	C	D	Ø
235-PVD	250	70	225	25
223-PVD	300	85	260	30
221-PVD	350	85	300	35

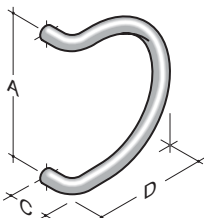

ART.	A	C	D	E	Ø
217-PVD	950	85	155	120	35

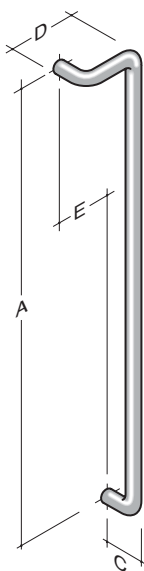

PROGRAMMA PVD

ART.	A	C	D	Ø
200-051-PVD	500	70	90	30
200-052-PVD	700	70	90	30

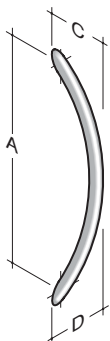

ART.	A	C	D	Ø
251-PVD	350	85	185	30

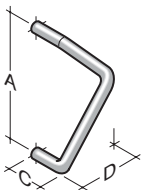

PROGRAMMA PVD

ART.	A	C	D	Ø
201-PVD	300	70	70	30
203-PVD	350	75	80	35

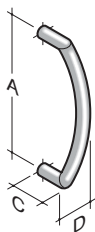

ART.	A	C	Ø
260-PVD	200	60	20

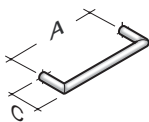

FISSAGGI SERIE /D
FIXINGS SERIES /D
FIXATIONS SERIE /D

BEFESTIGUNGEN SERIE /D
FIJACIONES SERIE /D
BEVESTIGING SERIE /D

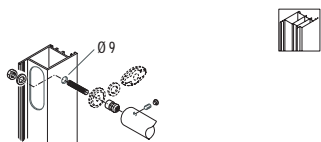

ART. 610/D-PVD

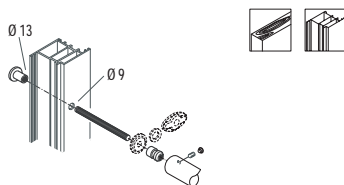

ART. 1110/D-PVD

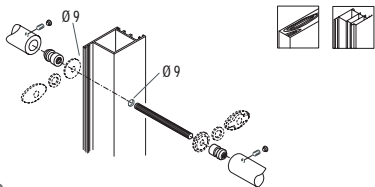

ART. 710/D-PVD

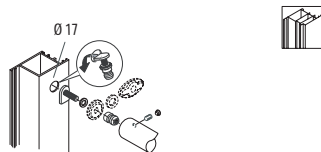

ART. 1210/D-PVD

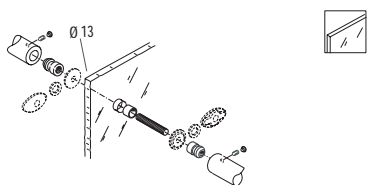

ART. 810/D-PVD

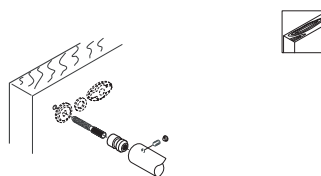

ART. 1310/D-PVD

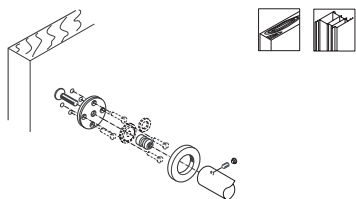

ART. 911/D - 912/D - 913/D - 914/D-PVD

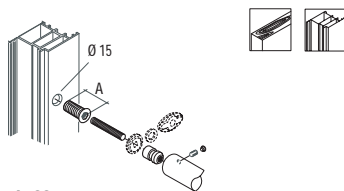

ART. 1410/D-PVD A=33 mm
ART. 1410/DL-PVD A=50 mm

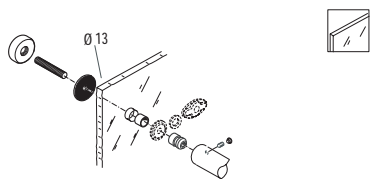

ART. 1011/D - 1012/D - 1013/D - 1014/D-PVD

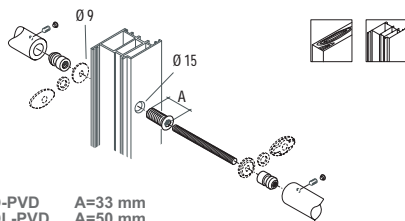

ART. 1510/D-PVD A=33 mm
ART. 1510/DL-PVD A=50 mm

LEGENDA - KEY TO SYMBOL - LÉGENDE - ZEICHENERKLÄRUNG - LEYENDA - LEGENDE

Legno
Wood
Holz
Bois
Madera
Hout

Alluminio / Pvc
Aluminium / Pvc
Aluminium / Pvc
Aluminium / Pvc
Aluminium / Pvc
Aluminium / Pvc

Vetro
Glass
Verre
Glass
Cristal
Glas

Spessori per protezione vetro in dotazione
Glass protections included
Protections pour verre incluses
Schutzteilen für Glas im Lieferumfang enthalten
Juntas de protección para cristal incluidas
Glasbeschermingsrubbers meegeleverd in de verpakking

**ITALIANO****PROGRAMMA P70**

Serie completa di limitatori di apertura per finestre a sporgere, a wasistas o con apertura verso l'esterno. Disponibili per tutti i tipi di profili e per il legno. Rigorosamente made in Italy.

Finitura standard: acciaio inox 18/8 (I), acciaio zincato (Z), alluminio grezzo (GZO), alluminio bronzo (BZO), alluminio elox pba (ELOX), alluminio argento (ARG).

DEUTSCH**PROGRAMMA P70**

Vollständige Serie von Fensterbeschläge für Kippfenster oder Wasistas. Für die Konstruktionen aller Art und für Holz.

Made in Italy.

Standardausführung: Edelstahl rostfrei (I), Stahl verzinkt (Z), Roh (GZO), Eloxiiert Bronze (BZO), Eloxiiert Pba (ELOX), Eloxiiert Silber (ARG).

ENGLISH**PROGRAMMA P70**

Complete range of opening restrictors for sash windows, transom windows or open outward. Available for all types of profiles and for wood. Precision manufactured in Italy.

Standard finishing: stainless steel 18/8 (I), galvanized steel (Z), raw (GZO), ox bronze (BZO), ox elox pba (ELOX), ox silver (ARG).

ESPAÑOL**PROGRAMMA P70**

Gama completa de dispositivos de limitación de apertura para ventanas saledizas, postigos o con apertura hacia el interior. Disponibles para todos los tipos de perfiles y para la madera. Rigurosamente hecho en Italia.

Acabados en serie: acero inoxidable 18/8 (I), acero galvanizado (Z), aluminio no acabado (GZO), aluminio bronce (BZO), aluminio elox pba (Elox), Aluminio plata (ARG).

FRANCAIS**PROGRAMMA P70**

Série complète de compas limiteurs d'ouverture pour fenêtres en saillie, châssis, avec ouverture vers l'extérieur. Disponibles pour tout type de profilés et pour bois. Exclusivement made in Italy.

Finition standard: acier inoxydable 18/8 (I), acier galvanisé (Z), alu brut (GZO), alu bronze (BZO), alu elox pba (ELOX), alu argent (ARG).

NEDERLANDS**PROGRAMMA P70**

Complete serie openingsbegrenzers voor naar buiten opengaande ramen, opvallende en openduwende ramen.

Beschikbaar voor alle types profielen en voor hout. Uitsluitend gefabriceerd in Italië. Gebruikt bevestigingen die het mogelijk maken om iedere greep zowel enkel als

per paar te bevestigen op elk materiaal (Hout, Metaal, PVC of glas).

Afwerking: roestvast staal 18/8 (I), verzinkt staal (Z), bruut aluminium (GZO), brons geanodiseerd aluminium (BZO), pba gelakt aluminium (ELOX), zilver geanodiseerd aluminium (ARG).

PROGRAMMA P70
ITALIANO

Specifiche d'ordine	Finiture	Confezioni Standard
Per tutti gli articoli: Codice articolo Tipologia di finitura	Standard: acciaio inox 18/8 (I)	P70-AS2-P 10 Coppie P70-AS2-PW 10 Coppie
	acciaio zincato (Z)	P70-AS2 15 Coppie P70-AS2W 15 Coppie
	alluminio grezzo (GZO)	P70-CF13 10 Coppie P70-AW4 20 Coppie
	alluminio bronzo (BZO)	P70-AW1 20 Coppie P70-AW1-C 20 Coppie
	alluminio elox pba (ELOX)	P70-F3 20 Pezzi P70-F5 50 Pezzi
	alluminio argento (ARG)	P70-F7 40 Pezzi P70-M12 200 Pezzi

ENGLISH

Order specifics	Finishes	Standard Packing
For all articles: Article code Type of finish	Standard production: stainless steel 18/8	P70-AS2-P 10 Pairs P70-AS2-PW 10 Pairs
	galvanized steel (I)	P70-AS2 15 Pairs P70-AS2W 15 Pairs
	raw aluminium (GZO)	P70-CF13 10 Pairs P70-AW4 20 Pairs
	ox bronze (BZO)	P70-AW1 20 Pairs P70-AW1-C 20 Pairs
	ox elox pba (ELOX)	P70-F3 20 Pieces P70-F5 50 Pieces
	ox silver (ARG)	P70-F7 40 Pieces P70-M12 200 Pieces

FRANCAIS

Caractéristiques de la commande	Finitions	Emballage standard
Pour tous les articles: Code article Typologie de finition	Production standard: acier inoxydable 18/8	P70-AS2-P 10 Paires P70-AS2-PW 10 Paires
	acier galvanisé (Z)	P70-AS2 15 Paires P70-AS2W 15 Paires
	alu brut (GZO)	P70-CF13 10 Paires P70-AW4 20 Paires
	alu bronze (BZO)	P70-AW1 20 Paires P70-AW1-C 20 Paires
	alu elox pba (ELOX)	P70-F3 20 Pièces P70-F5 50 Pièces
	alu argent (ARG)	P70-F7 40 Pièces P70-M12 200 Pièces

DEUTSCH

Bestellangabe	Ausführungen	Packeinheit zstück
Für alle Artikel: Artikelnummer Ausführung	Standard farbtafel: Edelstahl rostfrei (I)	P70-AS2-P 10 Paar P70-AS2-PW 10 Paar
	Stahl verzinkt (Z)	P70-AS2 15 Paar P70-AS2W 15 Paar
	Roh (GZO)	P70-CF13 10 Paar P70-AW4 20 Paar
	Eloxiert Bronze (BZO)	P70-AW1 20 Paar P70-AW1-C 20 Paar
	Eloxiert Pba (ELOX)	P70-F3 20 Stück P70-F5 50 Stück
	Eloxiert Silber (ARG)	P70-F7 40 Stück P70-M12 200 Stück

ESPAÑOL

Características del pedido	Acabados	Confección estándar
Para todos los artículos: Código artículo Tipo de acabado	Producción estándar: acero inoxidable 18/8	P70-AS2-P 10 Juegos P70-AS2-PW 10 Juegos
	galvanizado (I)	P70-AS2 15 Juegos P70-AS2W 15 Juegos
	aluminio no acabado (GZO)	P70-CF13 10 Juegos P70-AW4 20 Juegos
	aluminio bronce (BZO)	P70-AW1 20 Juegos P70-AW1-C 20 Juegos
	aluminio elox pba (Elox)	P70-F3 20 Piezas P70-F5 50 Piezas
	aluminio plata (ARG)	P70-F7 40 Piezas P70-M12 200 Piezas

NEDERLANDS

Besteidetails	Afwerkingen	Standaardverpakking
Voor alle artikelen: Artikelcode Afwerkingstype	Standaard: roestvast staal 18/8	P70-AS2-P 10 Paar P70-AS2-PW 10 Paar
	verzinkt staal (Z)	P70-AS2 15 Paar P70-AS2W 15 Paar
	bruut aluminium (GZO)	P70-CF13 10 Paar P70-AW4 20 Paar
	brons geanodiseerd aluminium (BZO)	P70-AW1 20 Paar P70-AW1-C 20 Paar
	pba gelakt aluminium (ELOX)	P70-F3 20 Stuks P70-F5 50 Stuks
	zilver geanodiseerd aluminium (ARG)	P70-F7 40 Stuks P70-M12 200 Stuks

LEGENDA - KEY TO SYMBOL - LÉGENDE - ZEICHENERKLÄRUNG - LEYENDA - LEGENDE



Apertura a wasistas
Opening for transom windows
Ouverture en vasistas
Öffnung für Wasistas
Apertura para postigo
Opennvallende opening



Apertura a sporgere
Opening for sash windows
Ouverture en saillie
Öffnung für Kipfenster
Apertura para ventanas saledizas
Opennduwende opening

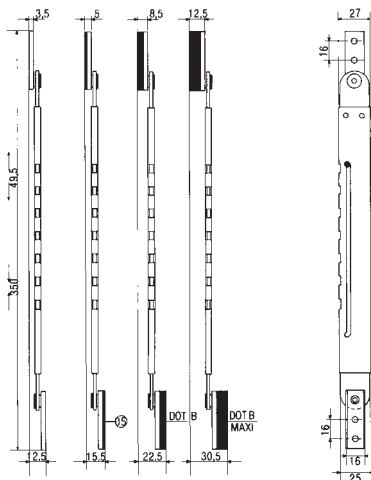

Arresti a 7 scatti.
 7 Restricted opening positions.
 Arrêts à 7 déclenchements.
 Fenster - Stopp mit 7 Rastungen.
 Bloqueos de 7 disparos.
 Begrenzer met 7 inrasteringen.



ART. P70-AS2-P-I
 ART. P70-AS2-P-Z

ART. P70-AS2-PW-I
 ART. P70-AS2-PW-Z

Kg 110 Kg. (cp)



Arresti a 4 scatti.
 4 Restricted opening positions.
 Arrêts à 4 déclenchements.
 Fenster - Stopp mit 4 Rastungen.
 Bloqueos de 4 disparos.
 Begrenzer met 4 inrasteringen.

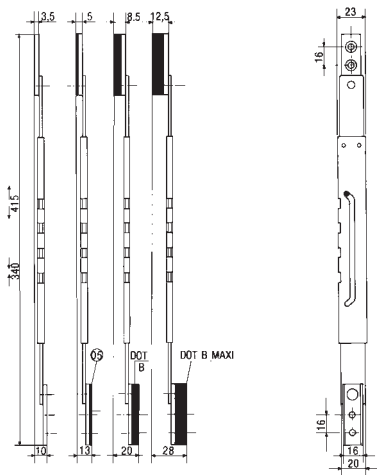

ART. P70-AS2-I
 ART. P70-AS2-Z

ART. P70-AS2-W-I
 ART. P70-AS2-W-Z

Kg 80 Kg. (cp)

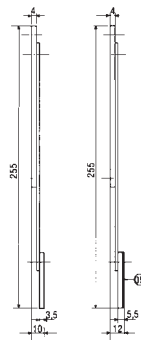
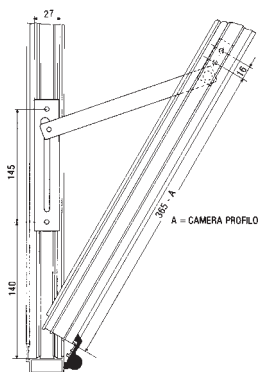

ART. P70-AW1



90 Kg. (cp)

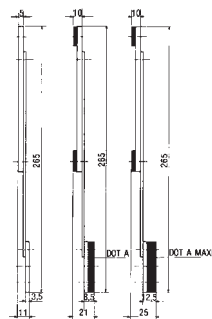
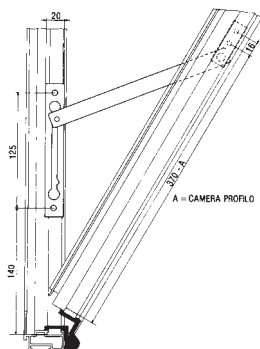

ART. P70-AW1-C



70 Kg. (cp)



ART. P70-F3



ART. P70-F5



ART. P70-F7

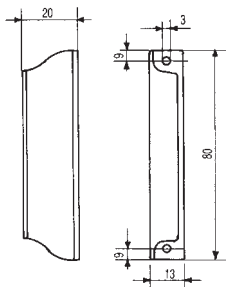

ART. P70-M12

PBA S.p.A.
Via Enrico Fermi, 1 - I-36056 Tezze sul Brenta (VI)
Tel. +39 0424 5451 - Fax +39 0424 545222
e-mail: info@pba.it - www.pba.it

PBA Deutschland GmbH
Raiffeisenstraße, 4a - D-83607 Holzkirchen
Tel. +49 8024 6084694 - Fax +49 8024 4749890
e-mail: info@de.pba.it - www.pba.it

